

6 months
WASH FILTER
Wash filter with cold water at least every 6 months.

REGISTER FOR YOUR FREE 5 YEAR GUARANTEE TODAY

ASSEMBLY

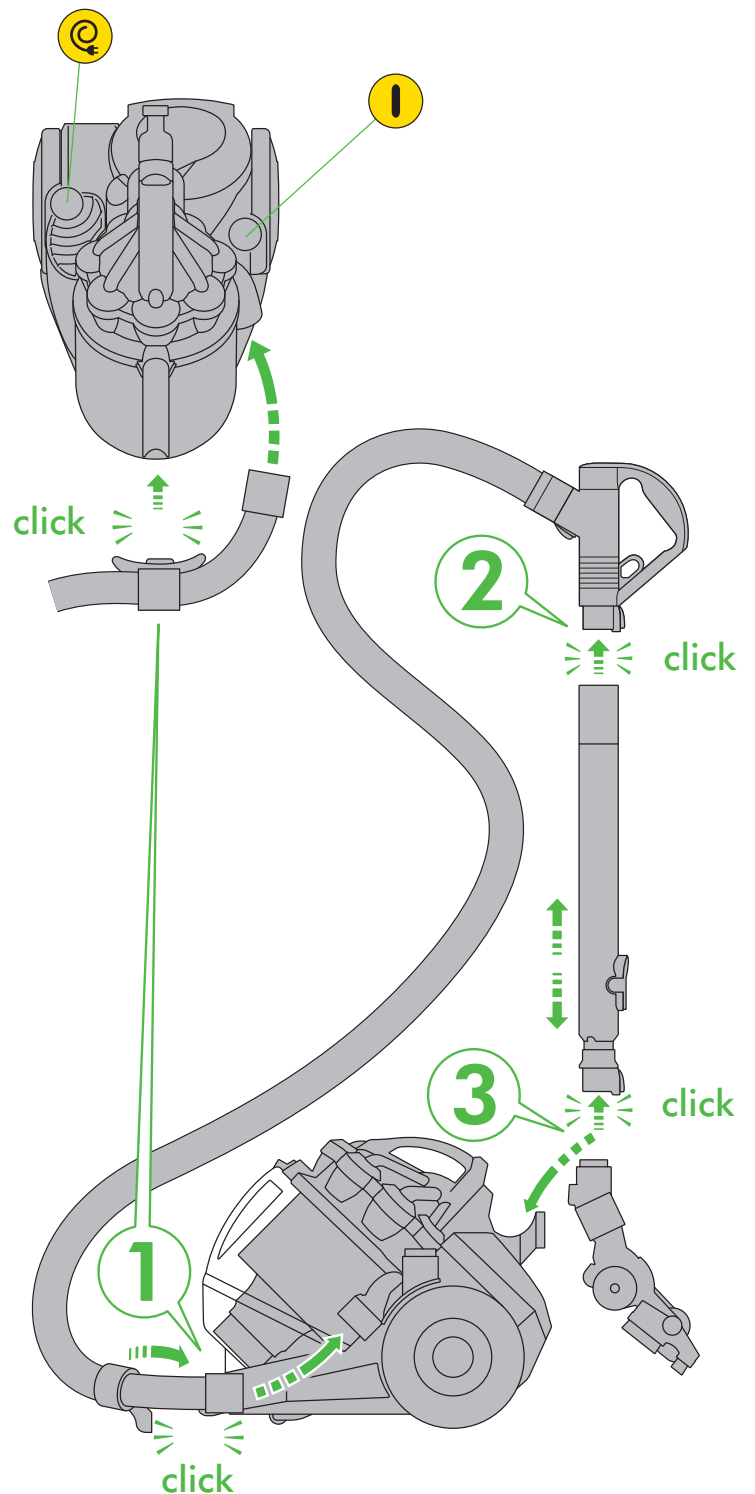

After registering for your 5 year guarantee, your Dyson vacuum cleaner will be covered for parts and labour for 5 years from the date of purchase, subject to the terms of the guarantee.

If you have any query about your Dyson vacuum cleaner, call the Dyson Customer Care Helpline with your serial number and details of where/when you bought the vacuum cleaner. Your serial number can be found on your rating plate which is behind the clear bin™.

Most queries can be solved over the phone by one of our trained Dyson Customer Care Helpline staff.

Alternatively visit www.dyson.co.uk/support for online help, general tips and useful information about Dyson.

Note your serial number for future reference



3 EASY WAYS TO REGISTER FOR YOUR FREE 5 YEAR GUARANTEE



REGISTER ONLINE

Visit our website to register your full parts and labour guarantee online.

www.dyson.com/register



REGISTER BY PHONE

Call our dedicated Helpline
Open 7am–10pm.
7 days a week.

UK 0800 298 0298
IRL 01 475 7109



REGISTER BY MAIL

Complete and return the form to Dyson in the envelope supplied.

IMPORTANT SAFETY PRECAUTIONS

READ ALL INSTRUCTIONS BEFORE USING THIS VACUUM CLEANER

When using an electrical appliance, basic precautions should always be followed, including the following:

WARNING

TO REDUCE THE RISK OF FIRE, ELECTRIC SHOCK, OR INJURY:

1. This vacuum cleaner is for domestic use only. Do not use outdoors or on wet surfaces.
2. Do not handle plug or vacuum cleaner with wet hands.
3. Do not allow to be used as a toy. Close attention is necessary when used by or near children.
4. Do not use with damaged cable or plug. If the supply cable is damaged, it must be replaced by Dyson Ltd., our service agents or similarly qualified persons in order to avoid a hazard.
5. If the vacuum cleaner is not functioning properly, has been dropped, damaged, left outdoors, or immersed in liquid, do not use. Contact the Dyson Customer Care Helpline.
6. Do not use the vacuum cleaner if any parts appear to be faulty, missing or damaged.
7. Ensure all parts, including the clear bin™, are securely attached before using or carrying the vacuum cleaner.
8. This vacuum cleaner is not intended for use by persons (including children) with reduced physical, sensory or mental capabilities, or lack of experience and knowledge, unless they have been given supervision or instruction concerning use of the vacuum cleaner by a person responsible for their safety. Children should be supervised to ensure that they do not play with the vacuum cleaner.
9. Do not leave vacuum cleaner when plugged in. Unplug from outlet when not in use, and before performing user maintenance, connecting or disconnecting the hose or changing accessories.
10. Store the vacuum cleaner indoors. Do not use or store this vacuum cleaner below 0°C (32°F). Ensure that the vacuum cleaner is at room temperature before operating. Put the vacuum cleaner away after use with the cable stored safely to prevent tripping hazards.
11. This vacuum cleaner is fitted with a thermal protection device. If any part of your vacuum cleaner becomes blocked it may cause the device to operate and automatically stop the vacuum cleaner. If this happens, the vacuum cleaner must be switched off, unplugged and allowed to cool down before attempting to check filters or for blockages. Ensure any blockage is cleared before re-starting the vacuum cleaner.
12. Turn off all controls before unplugging.
13. Do not unplug by pulling on cable. To unplug, grasp the plug, not the cable.
14. Do not pull or carry by the cable, use the cable as a handle, close a door on the cable, or pull the cable around sharp edges or corners. Do not run the vacuum cleaner over the cable. Keep the cable away from heated surfaces.
15. The use of an extension cable is not recommended.
16. Keep hair, loose clothing, fingers, and all parts of your body away from openings and moving parts, such as the brush bar.
17. Do not put any object into openings on the vacuum cleaner. Do not use with any opening blocked: keep free of dust, lint, hair, and anything that may reduce air flow.
18. Take extra care when vacuuming on stairs. Always work with the vacuum cleaner at the bottom of the stairs.
19. Keep the vacuum cleaner on the floor. Do not put the vacuum cleaner on chairs, tables etc.
20. Do not shake the vacuum cleaner or press the cyclone release button while carrying the vacuum cleaner, or it could fall and cause injury.
21. Do not use to pick up flammable or combustible liquids, such as petrol, or use in areas where they may be present.
22. Do not pick up anything that is burning or smoking, such as cigarettes, matches, or hot ashes.
23. Check to ensure your electricity supply matches that shown on the rating plate. The vacuum cleaner must only be used as rated.
24. Use only as described in this Dyson Operating Manual. Use only Dyson recommended attachments.
25. Do not use without the clear bin™ and filters in place.
26. Do not lubricate any parts, or carry out any maintenance or repair work other than that shown in this Dyson Operating Manual, or as advised by the Dyson Customer Care Helpline.

SAVE THESE INSTRUCTIONS

THIS VACUUM CLEANER IS INTENDED FOR HOUSEHOLD USE ONLY



Do not pull on the cable.



Do not store near heat sources.



Do not use near naked flame.



Do not run over the cable.



Do not pick up water or liquids.



Do not pick up burning objects.



Do not use above you on the stairs.



Do not put hands near the brush bar when the vacuum cleaner is in use.



Do not put your hands into the air duct leading to the pre-motor filter.

Power and cable

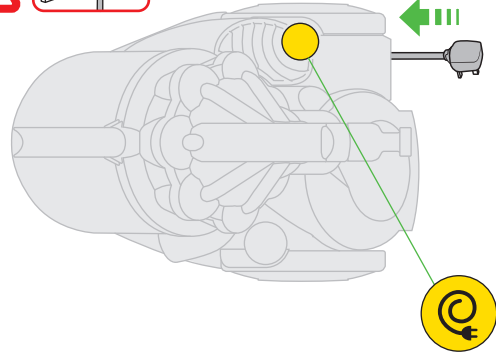
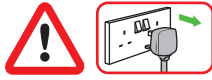
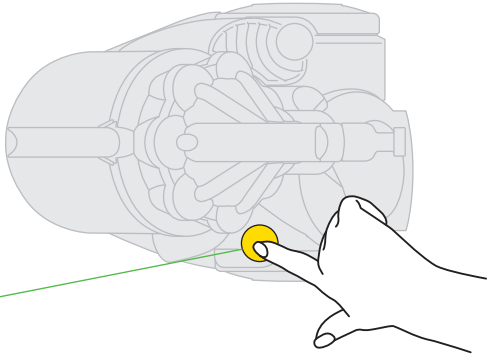
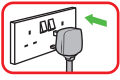

Emptying the clear bin™

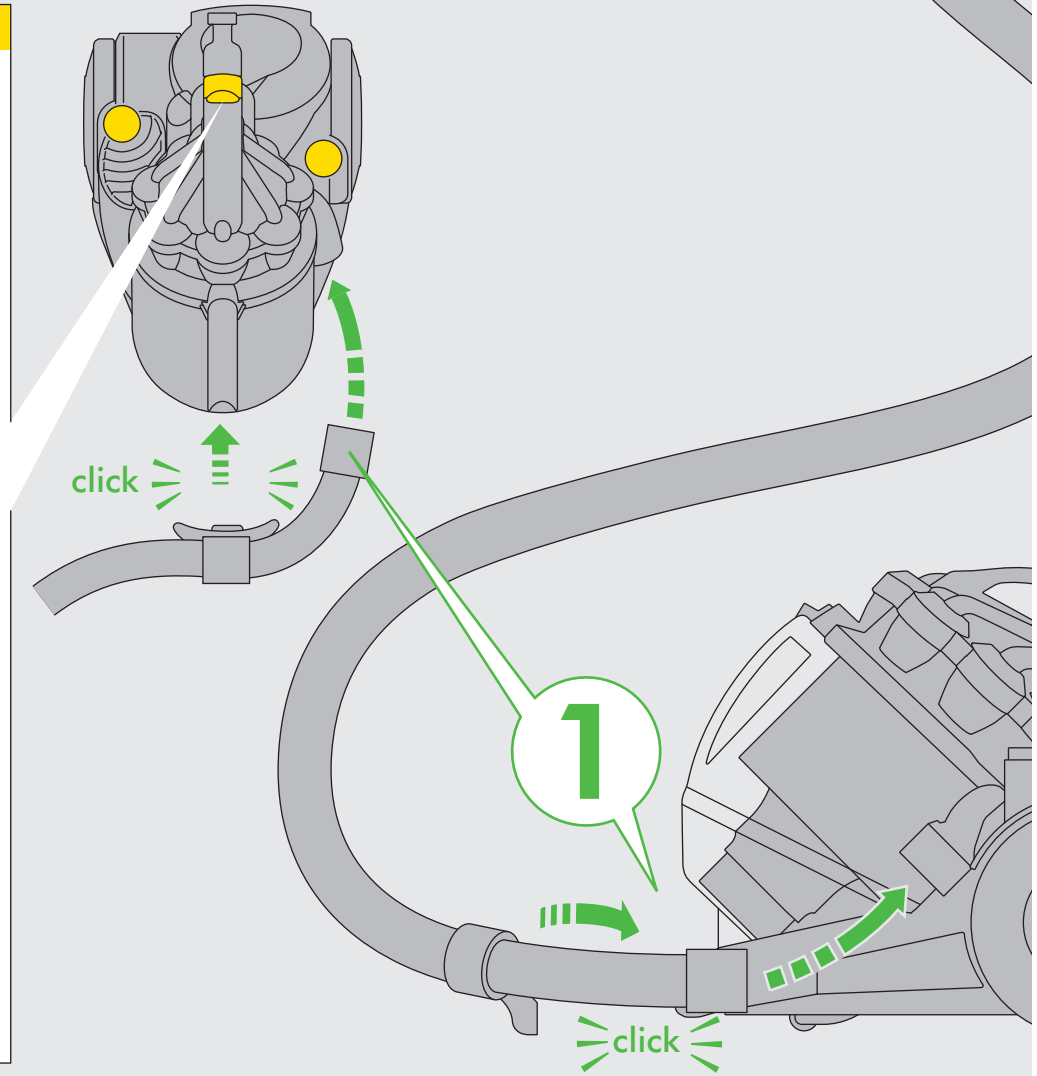
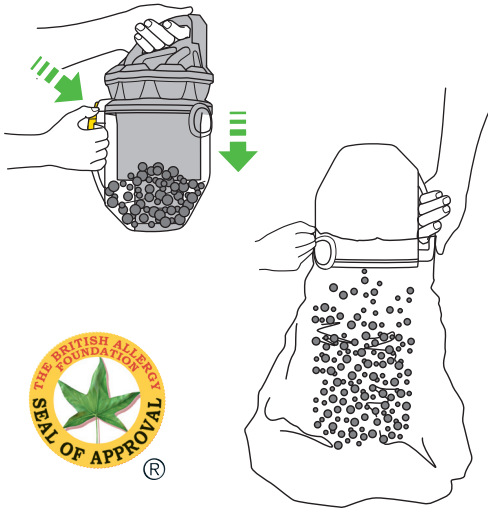
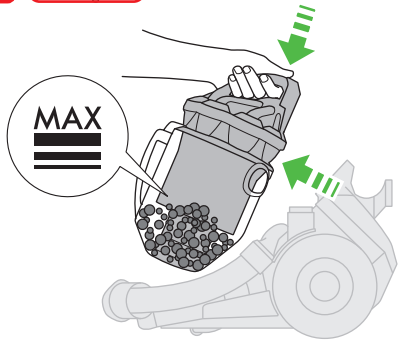
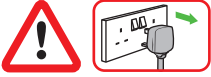

Cleaning the clear bin™

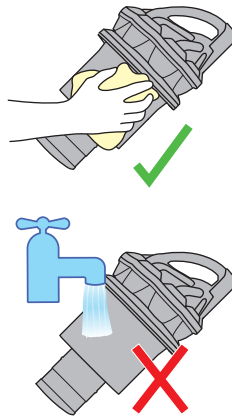
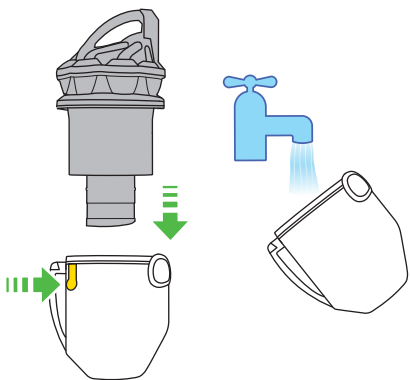

Looking for blockages

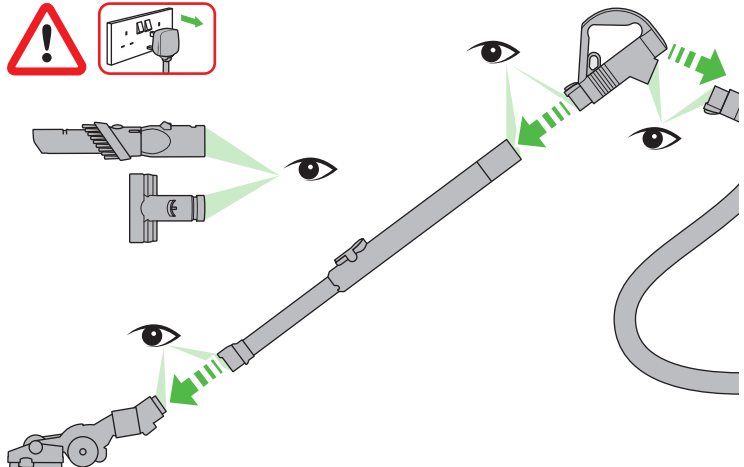
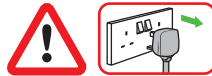

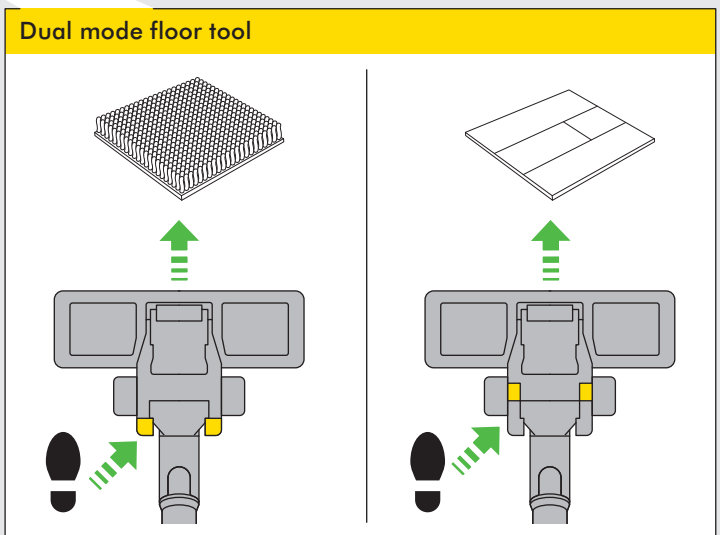
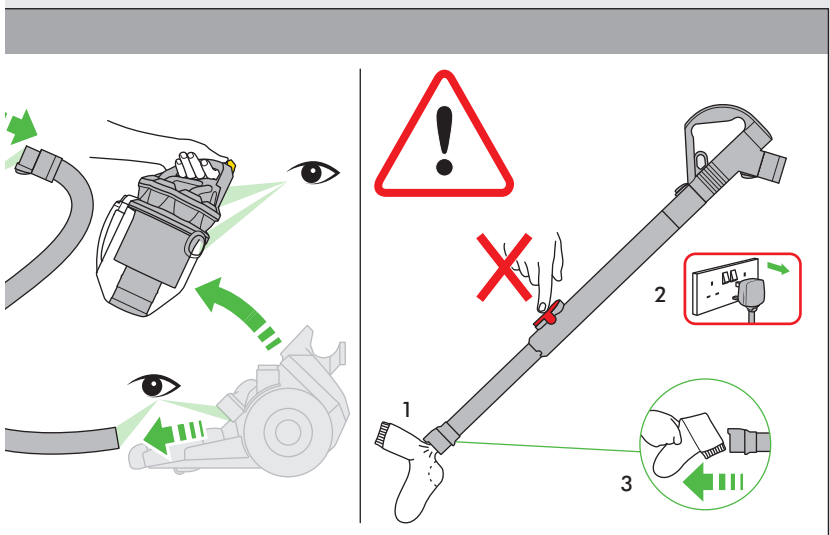
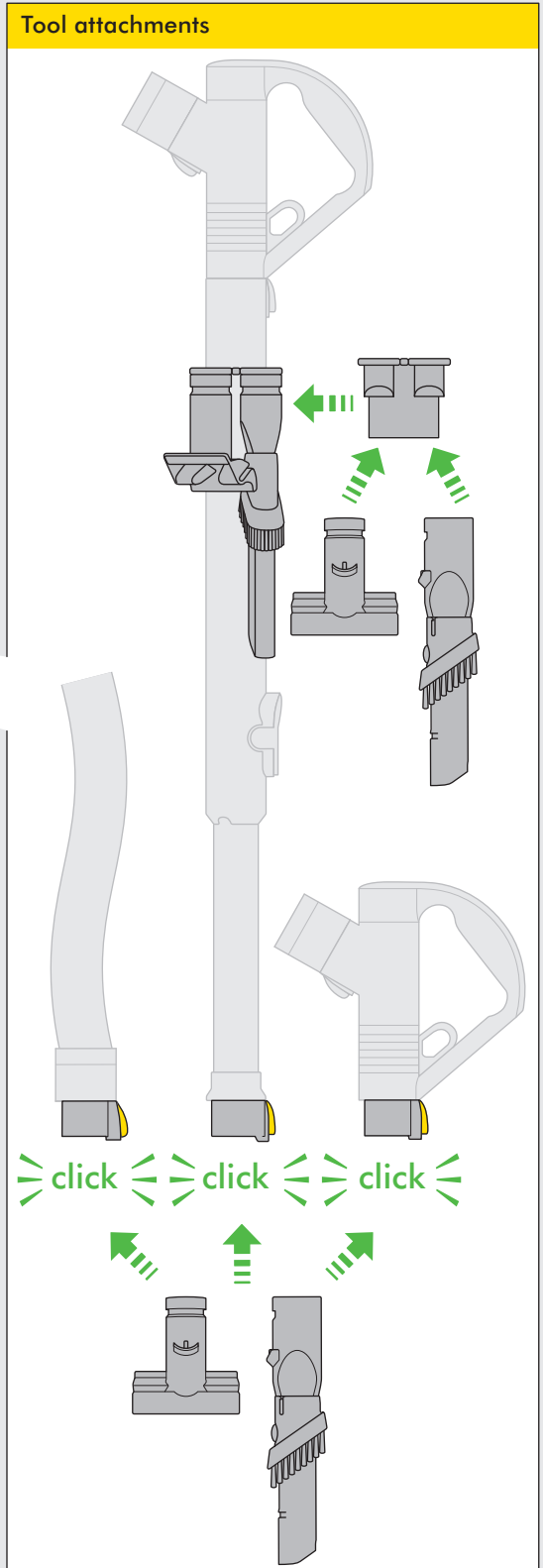
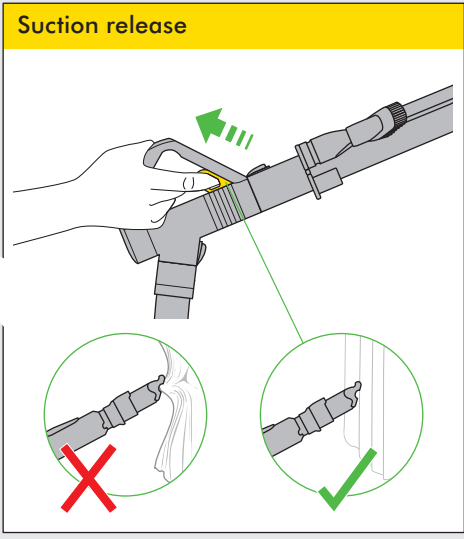
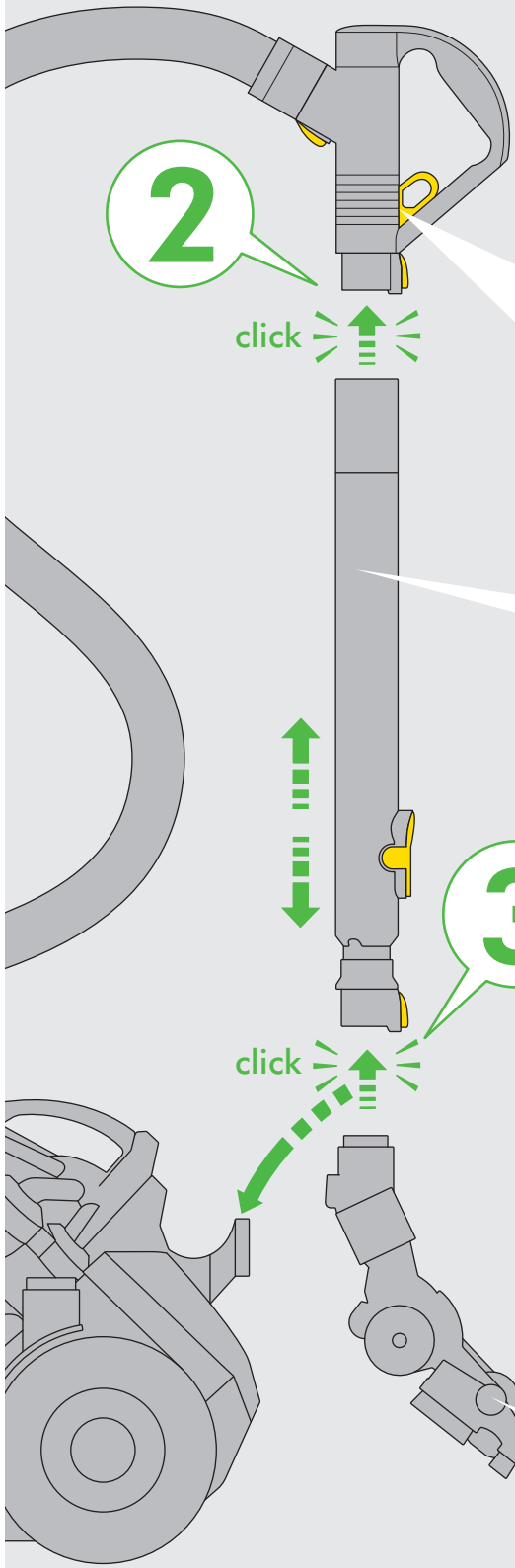

IMPORTANT!

WASH FILTER

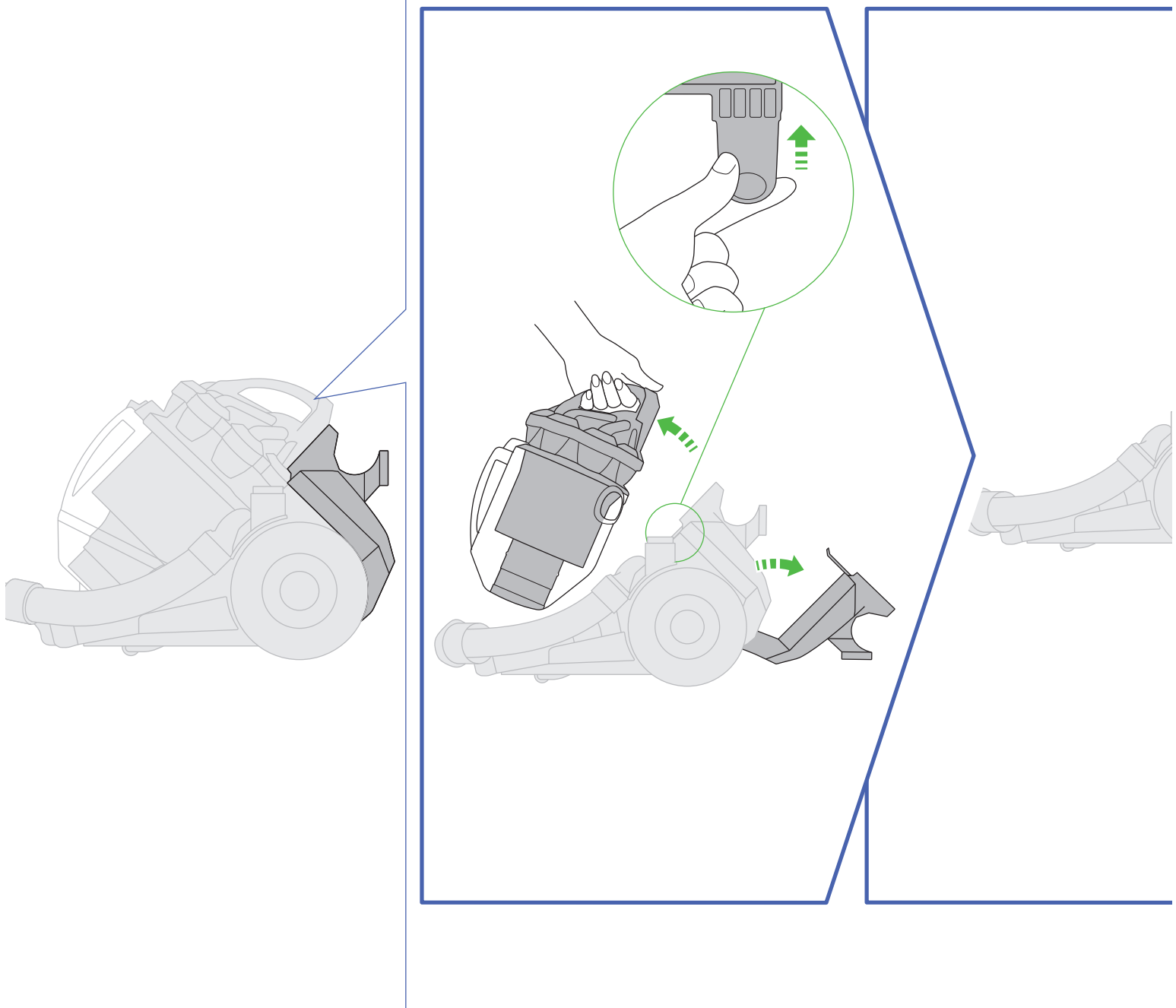
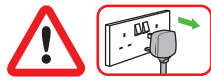

Wash filter with cold water at least every 6 months.

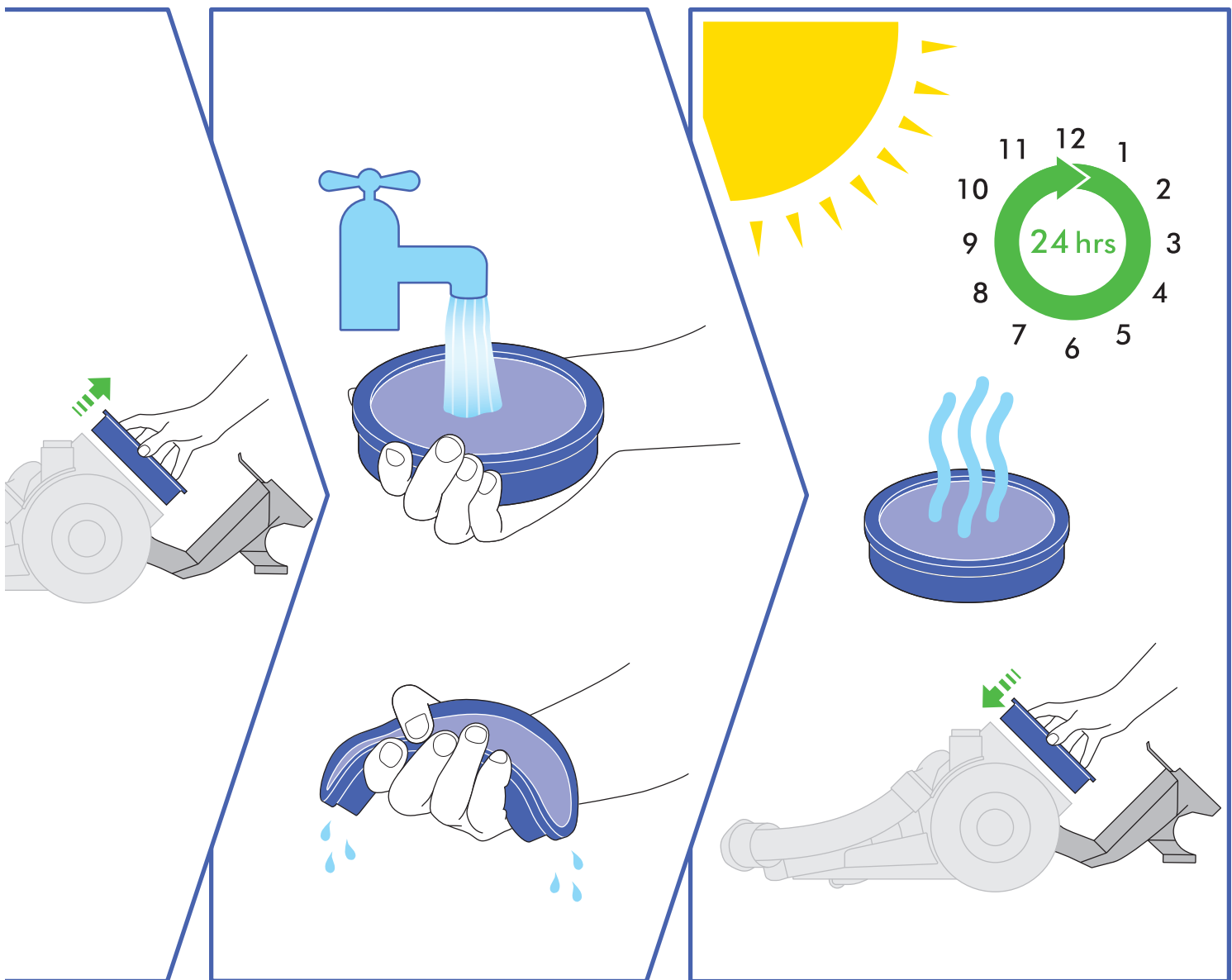

USING YOUR DYSON VACUUM CLEANER

PLEASE NOTE:

Always extend the cable fully to the red tape before use.

Fine dust such as plaster dust or flour should only be vacuumed in very small amounts.

Do not use the vacuum cleaner to pick up sharp hard objects, such as small toys, pins, paper clips etc.

Consult your flooring manufacturer's recommended instructions before vacuuming and caring for your floorings, rugs and carpets. Some carpets will fuzz if a rotating brush bar is used when vacuuming. If this happens, we recommend vacuuming in hard floors mode and consulting with your flooring manufacturer.

If used in a garage for car cleaning, care should be taken to wipe the soleplate and wheels with a dry cloth after vacuuming to clean off any sand, dirt or pebbles which could damage delicate floors.

When vacuuming, certain carpets may generate small static charges in the clear bin™. These are entirely harmless and not associated with the main supply. To minimise any effect from this, do not put your hand or insert any object into the clear bin™ unless you have emptied it and rinsed it out with cold water.

Only use parts recommended by Dyson; failure to do so could invalidate your guarantee.

EMPTYING THE CLEAR BIN™



CAUTION:

Switch OFF and unplug the vacuum cleaner before emptying the clear bin™. Empty as soon as the dirt reaches the level of the MAX mark – do not overfill. To remove the clear bin™ from the vacuum cleaner, press the button at the rear of the carrying handle. To release the dirt press the button on the front of the clear bin™.

The British Allergy Foundation is a UK national charity with the aim of improving awareness, prevention and treatment of allergies. The British Allergy Foundation Seal of Approval is a UK registered trademark.

PLEASE NOTE:

Do not use the vacuum cleaner without the clear bin™ in place.

To minimise dust and allergen contact when emptying, encase the clear bin™ tightly in a plastic bag and empty. Remove the clear bin™ carefully and seal bag tightly, dispose as normal.

CLEANING THE CLEAR BIN™



CAUTION:

Do not immerse the whole cyclone in water or pour water into the cyclones. Ensure the clear bin™ is completely dry before replacing.

Clean the shroud with a cloth or dry brush to remove lint and dust.

PLEASE NOTE:

Do not use detergents, polishes or air fresheners to clean the clear bin™.

Do not put the clear bin™ in a dishwasher.

WASHING YOUR FILTER



CAUTION:

Switch OFF and unplug the vacuum cleaner before removing the filter.

Ensure the filter is completely dry before refitting it to the vacuum cleaner.

PLEASE NOTE:

It is important to check your filter regularly and wash at least every six months, according to instructions, to maintain performance.

Please leave to dry completely for 24 hours.

The filter may require more frequent washing if vacuuming fine dust.

Do not use detergents to clean the filter.

Do not put the filter in a dishwasher, washing machine, tumble dryer, oven, microwave or near a naked flame.

LOOKING FOR BLOCKAGES



CAUTION:

Switch OFF and unplug the vacuum cleaner before checking for blockages.

Beware of sharp objects when clearing blockages.

Refit all parts of the vacuum cleaner securely before using.

PLEASE NOTE:

Clearing blockages is not covered by your vacuum cleaner's limited guarantee.

If any part of your vacuum cleaner becomes blocked, it may overheat and then automatically shut off. Unplug the vacuum cleaner and leave to cool down.

Clear any blockage before restarting.

Large items may block the tools or wand inlet, if this happens switch the vacuum cleaner off and unplug the vacuum cleaner before removing the blockage.

Do not operate the wand release catch.

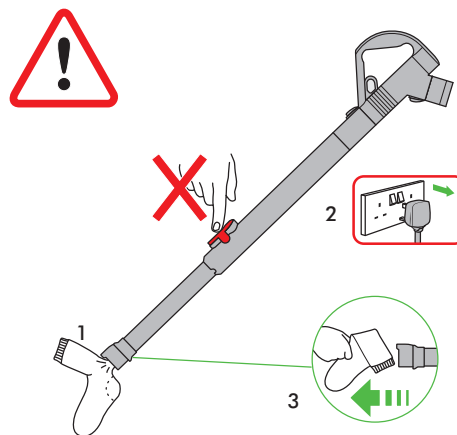

The symbol  on the product or on its packaging indicates that this product should not be treated as household waste. Instead it should be handed over to the applicable collection point for the recycling of electrical and electronic equipment – this may be your local civic amenity site or a facility provided by the retailer selling the product or a replacement product. By ensuring this product is disposed of correctly, you will help prevent potential negative consequences for the environment and for human health, which could otherwise be caused by inappropriate waste handling of this product. For more detailed information about recycling of this product, please contact the Dyson Customer Care Helpline, your local authority civic amenity site or the retailer selling the product or a replacement product.

CONFORMITY INFORMATION

A sample of this product has been tested and found to be in conformity with the following European Directives: 2006/95/EC Low voltage Directive, 93/68/EEC CE Marking Directive, 2004/108/EC EMC Directive.

GUARANTEE - TERMS AND CONDITIONS

DYSON CUSTOMER CARE

If you have a question about your Dyson vacuum cleaner, call the Dyson Customer Care Helpline with your serial number and details of where and when you bought the vacuum cleaner, or contact us via the website. The serial number can be found on the main body of the vacuum cleaner behind the clear bin™. Most questions can be solved over the phone by one of our Dyson Customer Care Helpline staff.

If your vacuum cleaner needs service, call the Dyson Customer Care Helpline so we can discuss the available options. If your vacuum cleaner is under guarantee, and the repair is covered, it will be repaired at no cost.

PLEASE REGISTER AS A DYSON OWNER

THANK YOU FOR CHOOSING TO BUY A DYSON VACUUM CLEANER

To help us ensure you receive prompt and efficient service, please register as a Dyson owner. There are three ways to do this:

Online at www.dyson.com/register

By calling the Dyson Customer Care Helpline: UK: 0800 298 0298 or IRL: 01 475 7109.

By completing and returning the enclosed form to us by mail. This will confirm ownership of your Dyson vacuum cleaner in the event of an insurance loss, and enable us to contact you if necessary.

LIMITED 5 YEAR GUARANTEE

TERMS AND CONDITIONS OF THE DYSON 5 YEAR LIMITED GUARANTEE.

WHAT IS COVERED

The repair or replacement of your vacuum cleaner (at Dyson's discretion) if your vacuum cleaner is found to be defective due to faulty materials, workmanship or function within 5 years of purchase or delivery (if any part is no longer available or out of manufacture Dyson will replace it with a functional replacement part). Use of the vacuum cleaner in the UK and Republic of Ireland.

WHAT IS NOT COVERED

Dyson does not guarantee the repair or replacement of a product as a result of: Normal wear and tear (e.g. fuse, belt, brush bar, batteries etc).

Accidental damage, faults caused by negligent use or care, misuse, neglect, careless operation or handling of the vacuum cleaner which is not in accordance with the Dyson Operating Manual.

Blockages – please refer to the Dyson Operating Manual for details of how to unblock your vacuum cleaner.

Use of the vacuum cleaner for anything other than normal domestic household purposes.

Use of parts not assembled or installed in accordance with the instructions of Dyson.

Use of parts and accessories which are not Dyson Genuine Components.

Faulty installation (except where installed by Dyson).

Repairs or alterations carried out by parties other than Dyson or its authorised agents.

If you are in any doubt as to what is covered by your guarantee, please call the Dyson Customer Care Helpline on UK: 0800 298 0298 or IRL: 01 475 7109.

SUMMARY OF COVER

The guarantee becomes effective at the date of purchase (or the date of delivery if this is later).

You must provide proof of delivery/purchase before any work can be carried out on your vacuum cleaner. Without this proof, any work carried out will be chargeable. Please keep your receipt or delivery note.

All work will be carried out by Dyson or its authorised agents.

Any parts which are replaced will become the property of Dyson.

The repair or replacement of your vacuum cleaner under guarantee will not extend the period of guarantee.

The guarantee provides benefits which are additional to and do not affect your statutory rights as a consumer.

ABOUT YOUR PRIVACY

Your information will be held by Dyson Ltd. and its agents for promotional, marketing and servicing purposes.

If your personal details change, if you change your mind about any of your marketing preferences or if you have any queries about how we use your information, please let us know by contacting

Dyson Ltd., Tetbury Hill, Malmesbury, Wiltshire, SN16 0RP England, or by calling the Dyson Customer Care Helpline on

UK 0800 298 0298 or IRL 01 475 7109.

Or you can email us at askdyson@dyson.co.uk

For more information on how we protect your privacy, please see our privacy policy on www.dyson.co.uk

PRODUCT INFORMATION

Maximum product weight 7.91kg, Voltage 230 – 240V, Maximum Power 1400W.

Please note: small details may vary from those shown.

This product is protected by the following intellectual property rights:

PATENT/PATENT APPLICATION NUMBERS

EP 1361812; EP 1361814; EP 1268076; EP 1361815; EP 0636338; EP 0800360; EP 1377196; GB 2416483; WO 2006/008451; EP 1542574; EP 1542576; GB 2407022; EP 1443842; EP 1443841.

Equivalent patents, registered designs and applications exist in other countries.

IMPORTANT!

WASH FILTER



Wash filter with cold water at least every 6 months.



Dyson Customer Care

If you have a question about your Dyson vacuum cleaner, call the Dyson Customer Care Helpline with your serial number and details of where and when you bought the cleaner, or contact us via the Dyson website. The serial number can be found on the main body of the vacuum cleaner behind the clear bin™.

UK Dyson Customer Care
askdyson@dyson.co.uk
0800 298 0298

Dyson Ltd, Tetbury Hill, Malmesbury, Wiltshire SN16 0RP.

IRL Dyson Customer Care
askdyson@dyson.co.uk
01 475 7109

Dyson Ireland Ltd, Unit 10 Greenogue Business Park,
Rothcoole, Dublin 24



GUARANTEE FORM

Date of purchase / /

Country of purchase UK IRL

Serial number

Title Surname

First name

Address

Postcode

e-mail

Telephone

Mobile

As a Dyson owner, you can hear about Dyson products, new ideas and inventions before anyone else. If it's okay to contact you, please let us know how we may do this.

Sometimes we might ask for feedback on our ideas or invite you to try new products and services. Would it be okay if our partner companies occasionally get in touch about this?

By mail Yes No

By phone Yes No

By email Yes No

By text message Yes No

Tick box if no

3 EASY WAYS TO REGISTER FOR YOUR FREE 5 YEAR GUARANTEE

REGISTER ONLINE

Visit our website to register your full parts and labour guarantee online.

www.dyson.com/register

REGISTER BY PHONE

Call our dedicated Helpline Open 7am-10pm. 7 days a week.

UK 0800 298 0298
IRL 01 475 7109

REGISTER BY MAIL

Complete and return the form to Dyson in the envelope supplied.