

3 months
WASH FILTER
Wash filter with cold water at least every 3 months.

A blue box containing a white icon of a vacuum cleaner with a circled "A" next to it. The text "3 months WASH FILTER" is prominently displayed, with "Wash filter with cold water at least every 3 months." written below it.

ASSEMBLY

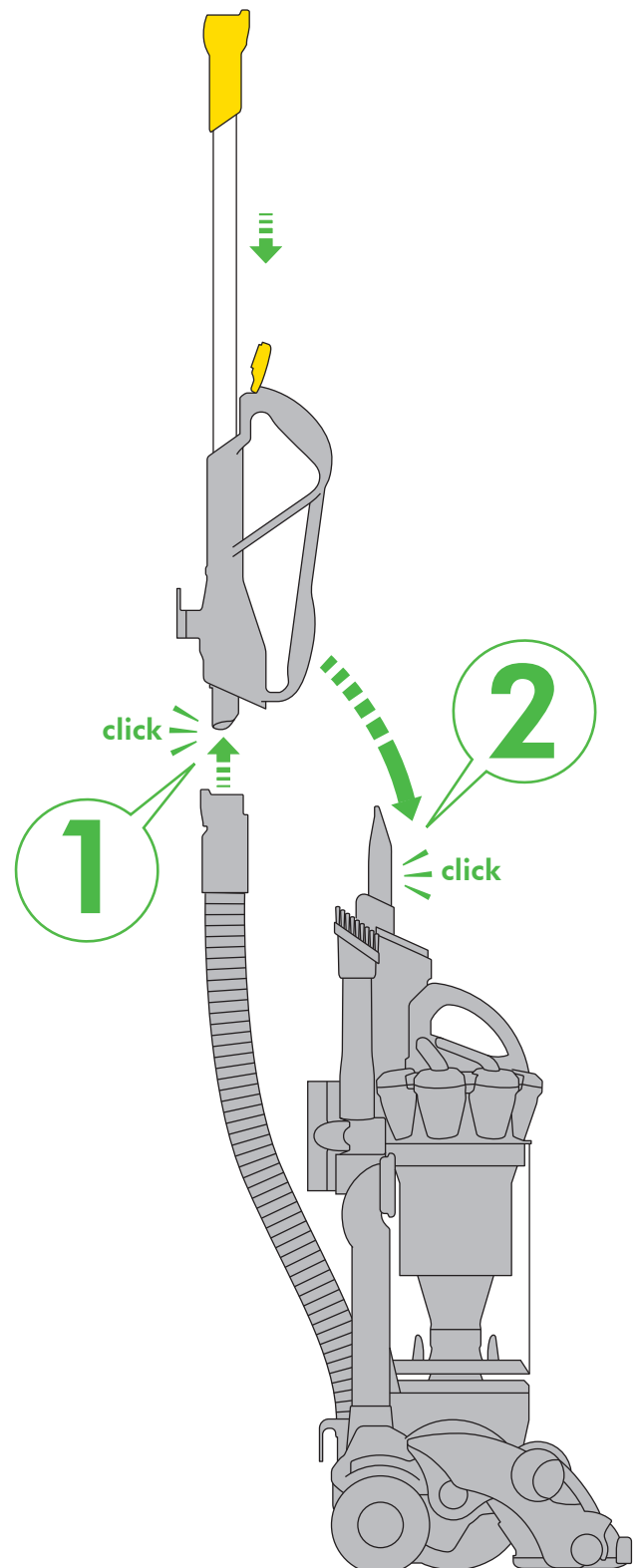

REGISTER
FOR YOUR
FREE 5 YEAR
GUARANTEE
TODAY



After registering for your 5 year guarantee, your Dyson vacuum cleaner will be covered for parts and labour for 5 years from the date of purchase, subject to the terms of the guarantee.

If you have any query about your Dyson vacuum cleaner, call the Dyson Customer Care Helpline with your serial number and details of where/when you bought the vacuum cleaner. Your serial number can be found on your rating plate which is behind the clear bin™.

Most queries can be solved over the phone by one of our trained Dyson Customer Care Helpline staff.

Note your serial number for future reference



3 EASY WAYS TO REGISTER FOR YOUR FREE 5 YEAR GUARANTEE



REGISTER ONLINE

Visit our website to register your full parts and labour guarantee online.

www.dyson.com/register



REGISTER BY PHONE

Call our dedicated Helpline
Open 7am–10pm.
7 days a week.

UK 0800 298 0298
IRL 01 475 7109



REGISTER BY MAIL

Complete and return the form to Dyson in the envelope supplied.

IMPORTANT SAFETY PRECAUTIONS

READ ALL INSTRUCTIONS BEFORE USING THIS VACUUM CLEANER

When using an electrical appliance, basic precautions should always be followed, including the following:

WARNING

TO REDUCE THE RISK OF FIRE, ELECTRIC SHOCK, OR INJURY:

1. Do not leave vacuum cleaner when plugged in. Unplug from outlet when not in use and before servicing.
2. Do not use outdoors or on wet surfaces.
3. Do not allow to be used as a toy. Close attention is necessary when used by or near children.
4. This vacuum cleaner is not intended for use by persons (including children) with reduced physical, sensory or mental capabilities, or lack of experience and knowledge, unless they have been given supervision or instruction concerning use of the appliance by a person responsible for their safety.
5. Use only as described in this manual. Use only Dyson recommended attachments.
6. Do not use with damaged cable or plug. If the supply cable is damaged, it must be replaced by Dyson Ltd, our service agent or similarly qualified persons in order to avoid a hazard. If vacuum cleaner is not working as it should, has been dropped, damaged, left outdoors, or dropped into water, do not use, contact the Dyson Customer Care Helpline.
7. Do not pull or carry by cable, use cable as a handle, close a door on cable, or pull cable around sharp edges or corners. Do not run vacuum cleaner over cable. Keep cable away from heated surfaces.
8. Do not unplug by pulling on cable. To unplug, grasp the plug, not the cable.
9. Do not handle plug or vacuum cleaner with wet hands.
10. Do not put any object into openings. Do not use with any opening blocked; keep free of dust, lint, hair, and anything that may reduce air flow.
11. Keep hair, loose clothing, fingers, and all parts of body away from openings and moving parts, such as the brush bar.
12. Turn off all controls before unplugging.
13. Use extra care when cleaning on stairs.
14. Do not use to pick up flammable or combustible liquids, such as petrol, or use in areas where they may be present.
15. Do not pick up anything that is burning or smoking, such as cigarettes, matches, or hot ashes.
16. Do not use without clear bin™ and filters in place.

SAVE THESE INSTRUCTIONS

THIS VACUUM CLEANER IS INTENDED FOR HOUSEHOLD USE ONLY

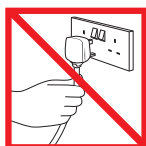

Do not pull on the cable.

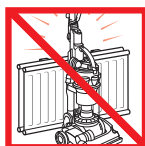

Do not store near heat sources.



Do not use near naked flame.

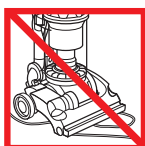

Do not run over the cable.



Do not pick up water or liquids.



Do not pick up burning objects.



Do not use above you on the stairs.



Do not put hands near the brush bar when the vacuum cleaner is in use.

Using your Dyson vacuum cleaner

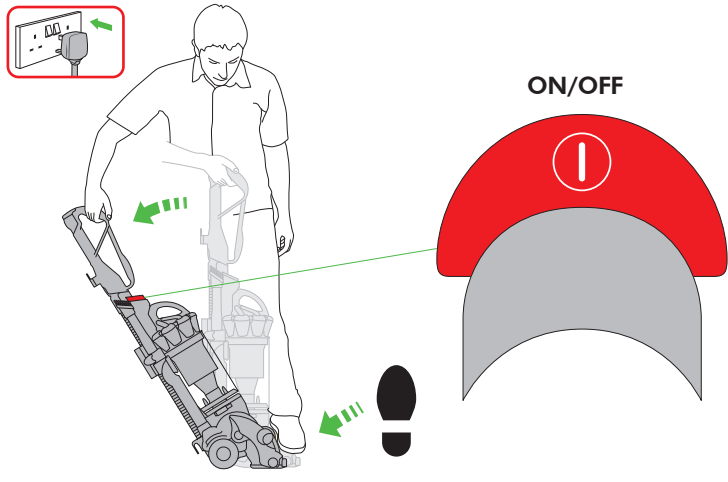

Carrying your Dyson vacuum cleaner

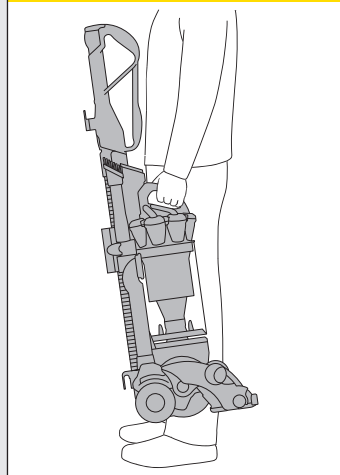

Looking fo

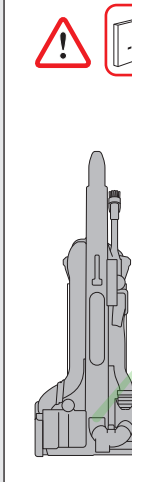

Clear bin™ emptying

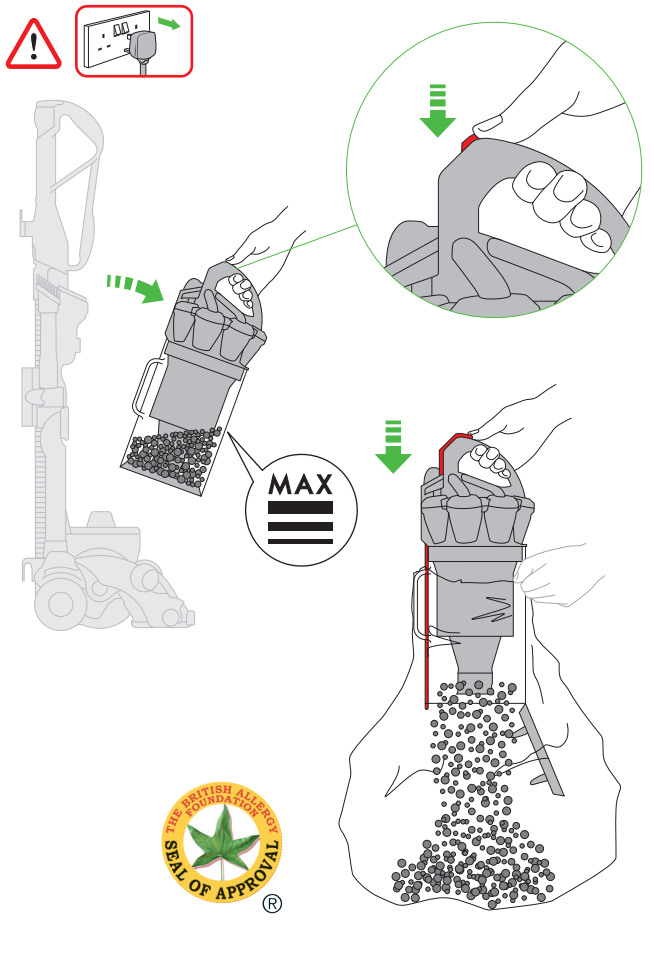

1

click

click

Clearing brush bar obstructions

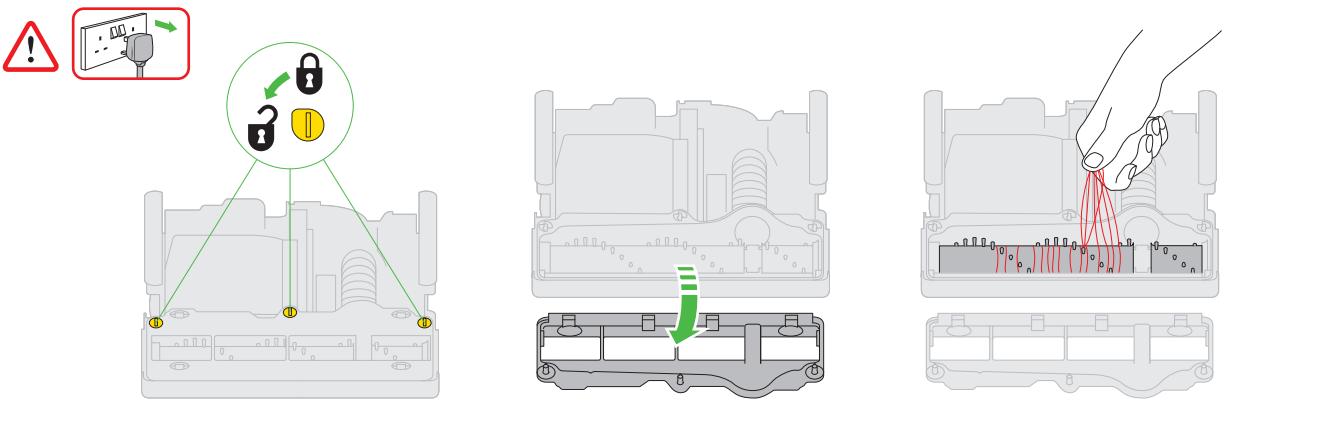

Carpets/Hard fl

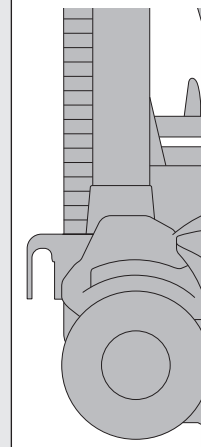

ing for blockages

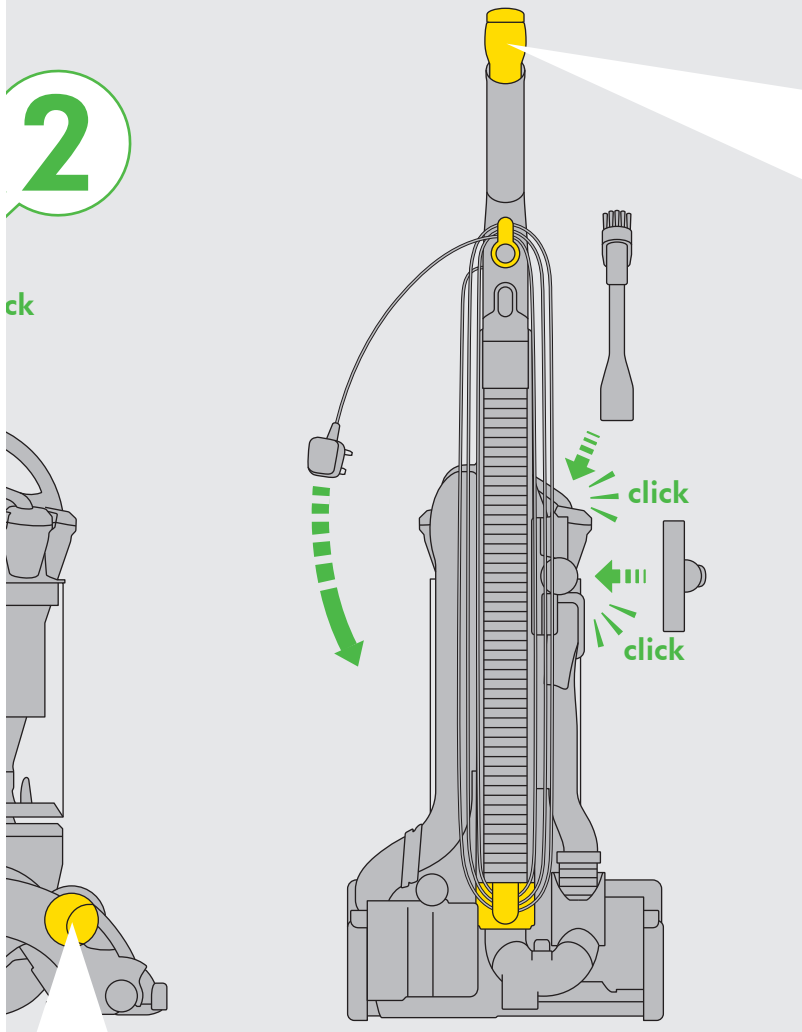
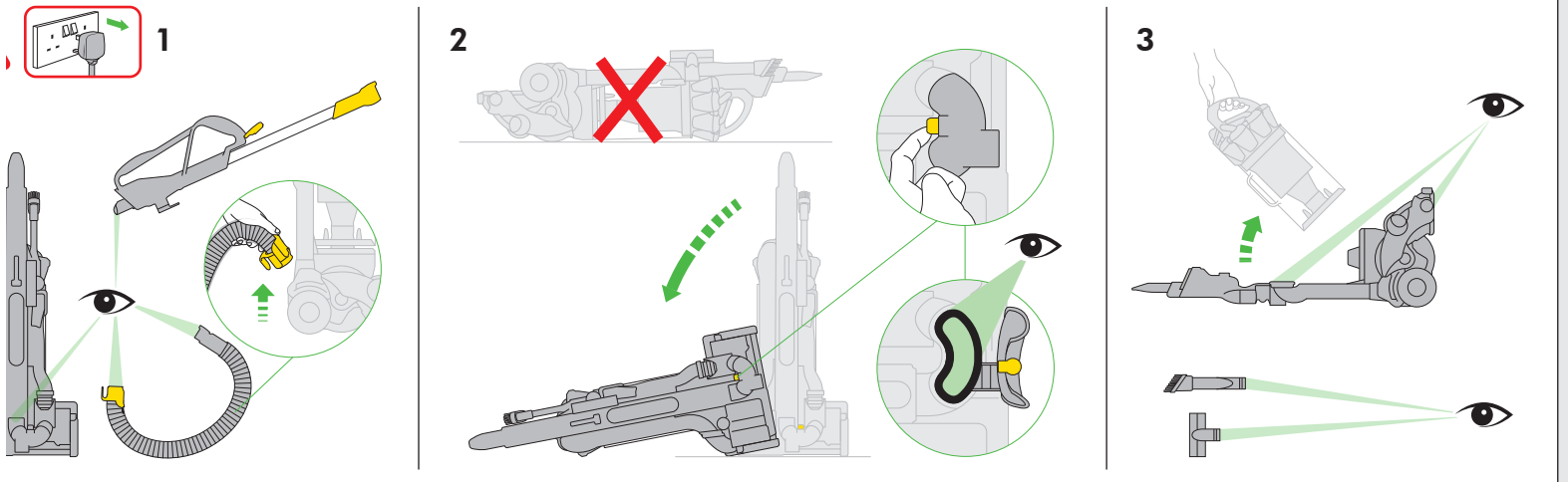

High-reach cleaning

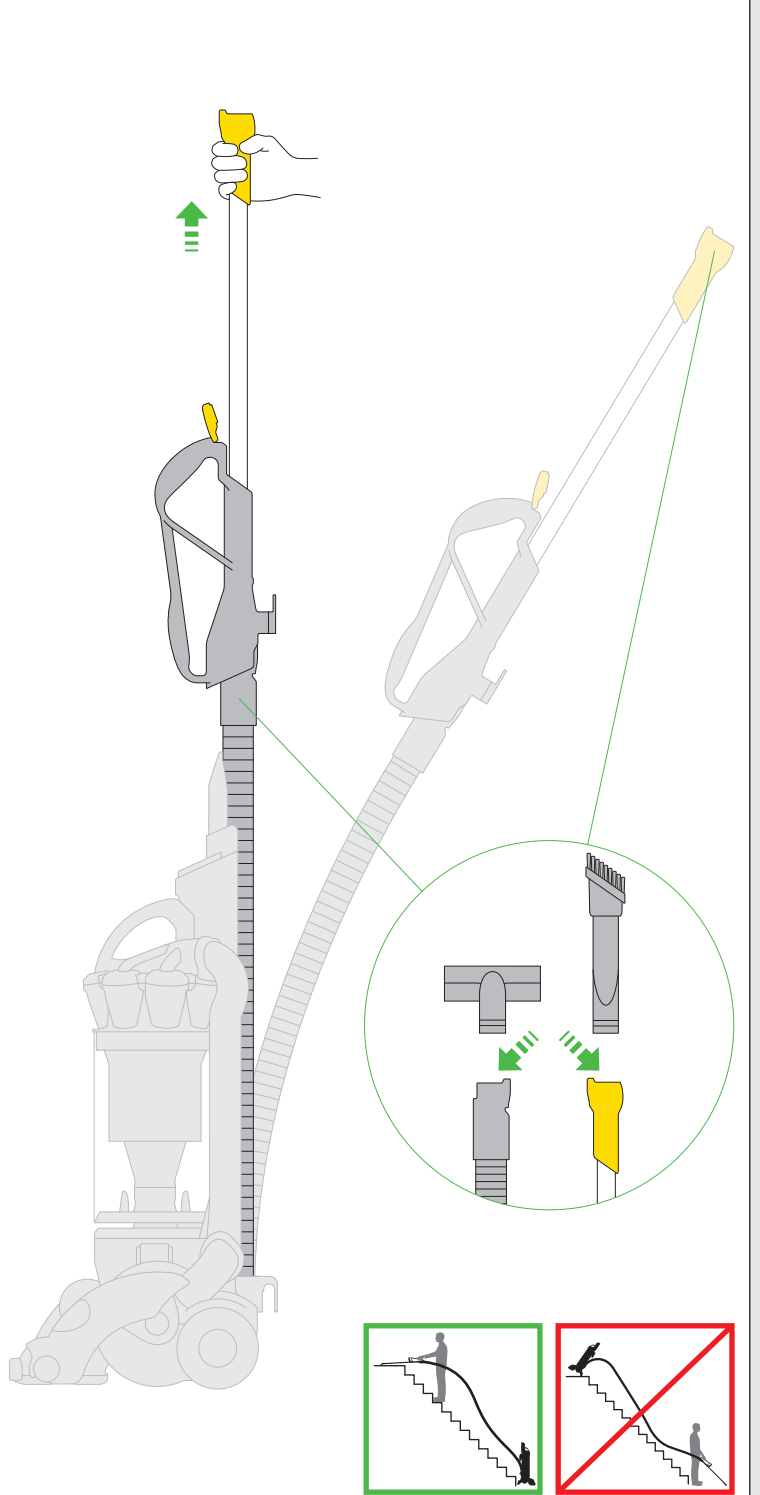

rd floors

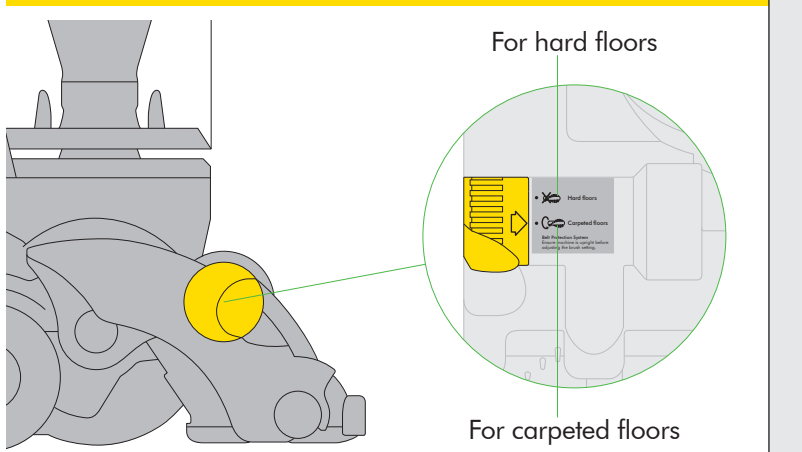

IMPORTANT!

WASH FILTER

 **3**
months

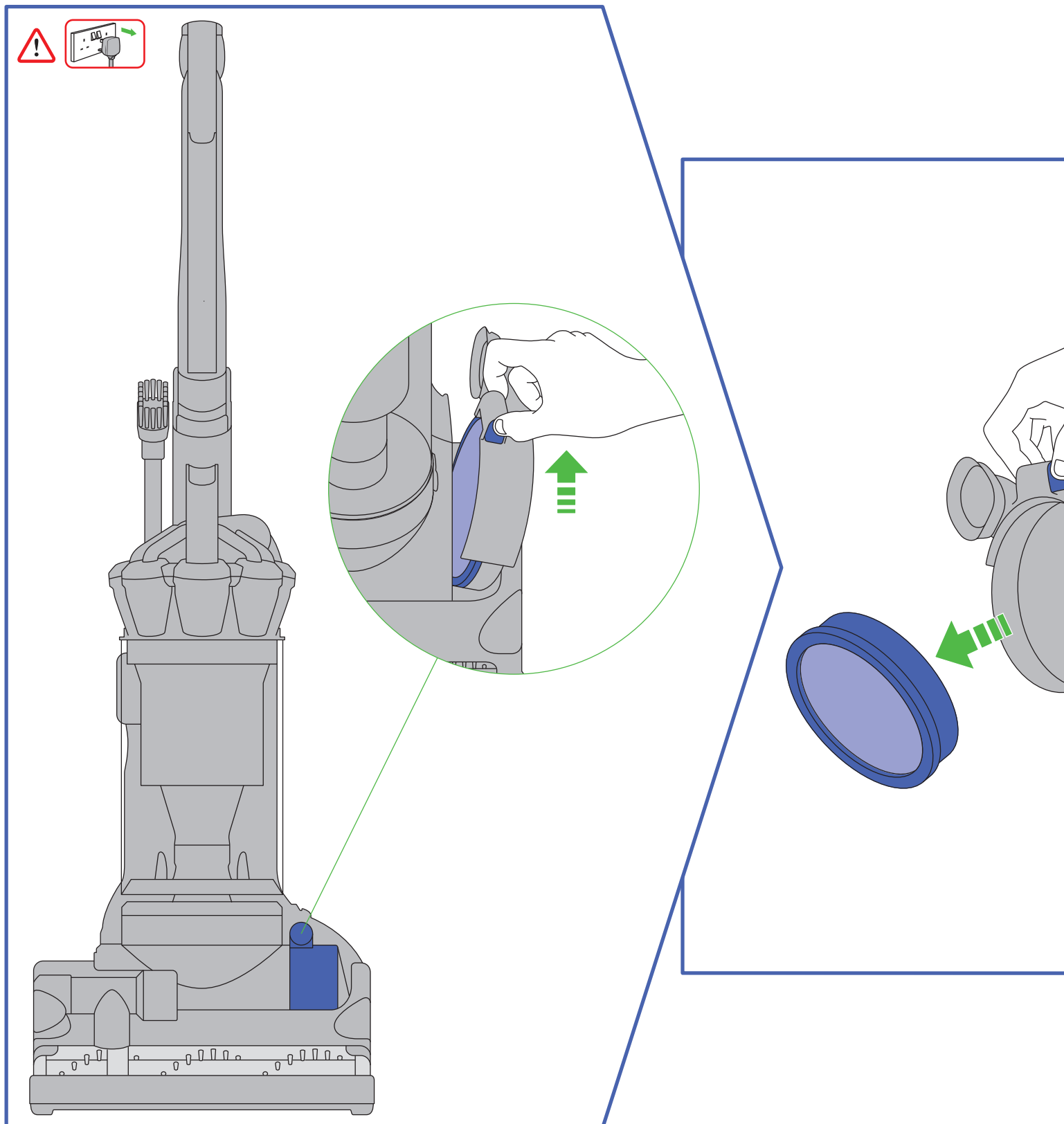

Wash filter with cold water at least every 3 months.

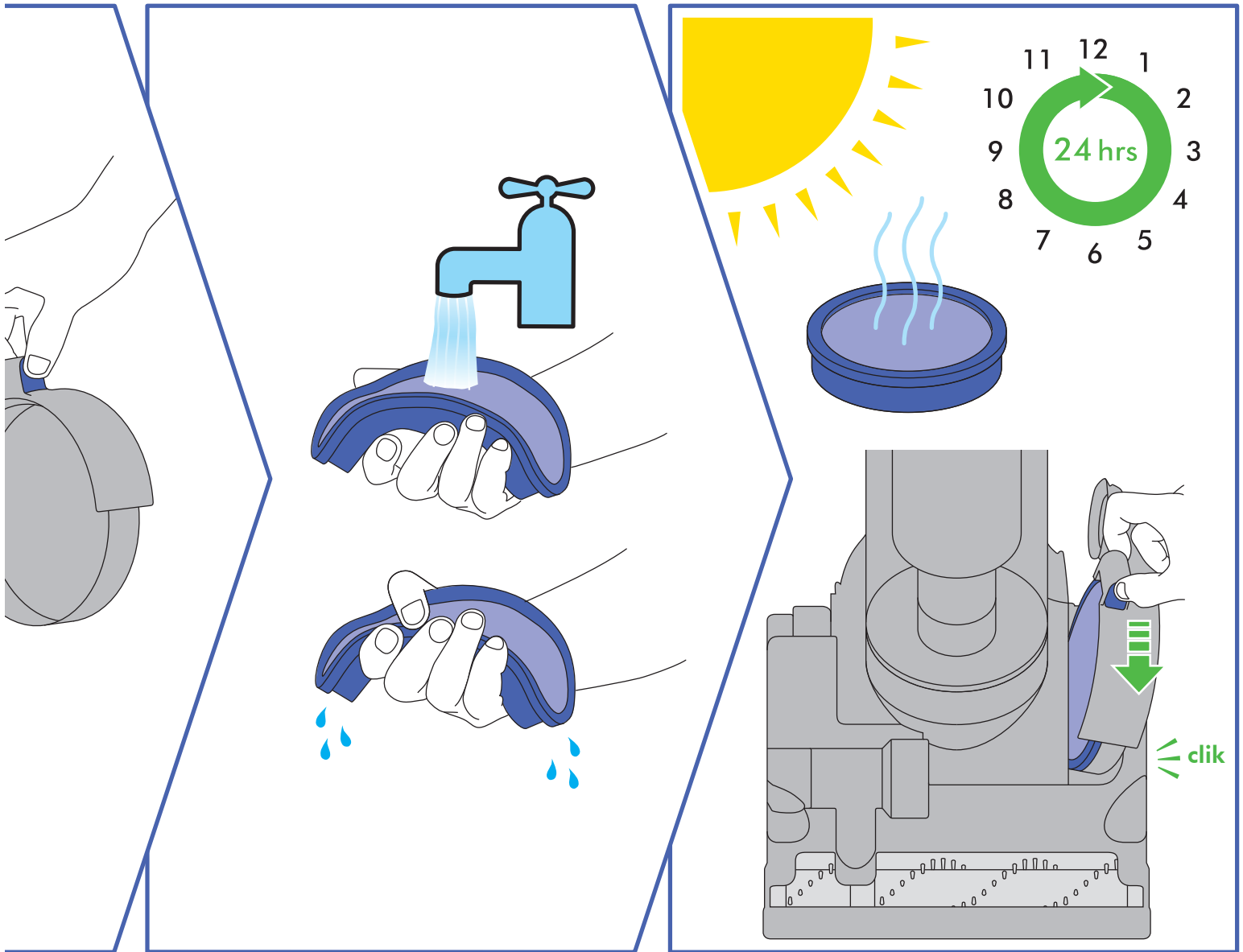

ASSEMBLY

- Stand the vacuum cleaner up straight and slide the hose into guides at the back of the vacuum cleaner and click into place.
- Ensure the hose is straight and slide the wand straight down into the hose until it clicks into place.
- Click the wand handle into the top of the vacuum cleaner.
- Attach the tools to the vacuum cleaner and wind the cable counter-clockwise around cable hooks and secure with clip.

USING YOUR DYSON VACUUM CLEANER

Unwind the cable and insert the plug into a suitable socket.
Hold the cleaner head down with your foot and pull the handle downwards.
To switch 'ON' or 'OFF' press the power button in front of the handle.

CAUTION:

- Do not allow the vacuum cleaner to be used by anyone who may not be able to operate it safely.
- The use of an extension cable is not recommended.
- Always switch off and unplug before performing maintenance on your vacuum cleaner.
- When returning to the upright position, ensure that the wand and clear bin™ assembly are fully upright before releasing the vacuum cleaner.
- Ensure the cyclone is secured to the vacuum cleaner. Do not press the cyclone release button or shake the vacuum cleaner while carrying or it could fall and cause injury.
- Store the vacuum cleaner indoors. Put the vacuum cleaner away after use with the cable coiled safely, to prevent tripping hazards.
- Do not use outdoors or on wet surfaces or to vacuum water or other liquids – electric shock could occur.
- Do not lubricate any parts, or carry out any maintenance or repair work other than that shown in this manual, or advised by the Dyson Customer Care Helpline.

PLEASE NOTE:

- This vacuum cleaner is intended for domestic use only. Fine dust such as plaster dust or flour should only be vacuumed in very small amounts.
- Do not use the vacuum cleaner to pick up sharp hard objects, small toys, pins, paper clips, etc. They may damage the vacuum cleaner.
- If used in a garage, care should be taken to wipe the soleplate and wheels with a dry cloth after vacuuming to clean off any sand, dirt, or pebbles that could damage delicate floors.
- Consult your flooring manufacturer's recommended instructions before vacuuming and caring for your flooring, rugs, and carpet. Some carpets will fuzz if a rotating brush bar is used when vacuuming. If this happens, we recommend vacuuming in hard floors mode and consulting with your flooring manufacturer.
- When vacuuming, certain carpets may generate small static charges in the clear bin™. These are entirely harmless and are not associated with the mains supply. To minimise any effect from this, do not put your hand or insert any object into the clear bin™ unless you have first emptied it and rinsed it out with cold water. (See 'Clear bin™ cleaning' section.)

CARPETS/HARD FLOORS

When you switch the machine on for the first time, the brush bar will default to ON (spinning). The brush bar will automatically stop if it becomes obstructed. If the brush bar stops during use, please refer to the "Clear brush bar obstructions" section. To switch the brush bar OFF (eg. for use on hard floors), recline the vacuum cleaner and turn the brush bar ON/OFF control on the cleaner head to the OFF position. The brush bar will remain OFF until it is turned back to ON at a later date.

HIGH-REACH CLEANING

CAUTION:

- Switch 'OFF' the vacuum cleaner before changing tools.
- Powerful suction can cause the hose to 'pull back' - please take care.
- Take extra care when vacuuming on stairs; do not work with the vacuum cleaner above you on the stairs. Do not put the vacuum cleaner on chairs, tables etc.
- Ensure vacuum cleaner is in upright position before using tools.

PLEASE NOTE:

- To release the wand, open the wand cap and pull the red tube until the wand releases from the vacuum cleaner. Tools can be attached to either the hose or wand.
- The brush bar will not rotate when the vacuum cleaner is in an upright position.
- Ensure wand cap is closed when not in use.

CLEAR BIN™ EMPTYING

CAUTION:

- Switch 'OFF' the vacuum cleaner and unplug before emptying the clear bin™.

PLEASE NOTE:

- Empty as soon as the dirt reaches the level of the MAX mark – do not overfill.
 - To remove the clear bin™ from the vacuum cleaner, press the red button at the rear of cyclone carrying handle. To release the dirt, press the red bin release button.
- The British Allergy Foundation is a UK national charity with the aim of improving awareness, prevention and treatment of allergies. The British Allergy Foundation Seal of Approval is a UK registered trademark.
- Do not use the vacuum cleaner without the clear bin™ in place.

CLEAR BIN™ CLEANING

CAUTION:

- Do not immerse the whole cyclone in or pour water into the cyclones.
- Ensure the clear bin™ is completely dry before replacing.

PLEASE NOTE:

- Do not use detergents, polishes or air fresheners to clean the clear bin™.
- Do not put clear bin™ in a dishwasher.

WASHING YOUR FILTER

DO THIS EVERY 3 MONTHS

CAUTION:

- Switch 'OFF' and unplug the vacuum cleaner before removing the filter.
- Ensure filter is completely dry before refitting to the vacuum cleaner.

PLEASE NOTE:

- This vacuum cleaner has one washable filter, located as shown. It is important to check your filter regularly and wash at least every 3 months according to instructions, to maintain performance.
- After washing please leave for 24 hours to dry completely.
- It is normal for filter to turn grey in colour. The filter may require more frequent washing if vacuuming fine dust.
- Do not use detergents to clean the filter.
- Do not put the filter in a dishwasher, washing machine, tumble dryer, oven, microwave or near a naked flame.

LOOKING FOR BLOCKAGES

CAUTION:

- Switch 'OFF' and unplug the vacuum cleaner before checking for blockages. Failure to do so could result in personal injury.
- Please ensure the vacuum cleaner is upright and switched off before removing hose or airway inspection parts.
- Beware of sharp objects when clearing blockages.
- Refit all parts of the vacuum cleaner securely before using.

PLEASE NOTE:

- Clearing blockages is not covered by your vacuum cleaner's limited guarantee.
- This vacuum cleaner is fitted with a thermal cut-out. If any part of the vacuum cleaner becomes blocked, it may overheat and automatically cut-out. Switch 'OFF' and unplug the vacuum cleaner and leave to cool down before checking filter or for blockages.

CLEARING BRUSH BAR OBSTRUCTIONS

CAUTION:

- Switch 'OFF' and unplug the vacuum cleaner before clearing brush bar obstructions. Failure to do so could result in personal injury.
- Beware of sharp objects when clearing obstructions.
- Refit all parts of the vacuum cleaner securely before using.

PLEASE NOTE:

- Clearing brush bar obstructions is not covered by your vacuum cleaner's limited guarantee.

The symbol  on the product or on its packaging indicates that this product should not be treated as household waste. Instead it should be handed over to the applicable collection point for the recycling of electrical and electronic equipment – this may be your local civic amenity site or a facility provided by the retailer selling the product or a replacement product. By ensuring this product is disposed of correctly, you will help prevent potential negative consequences for the environment and for human health, which could otherwise be caused by inappropriate waste handling of this product. For more detailed information about recycling of this product, please contact the Dyson Customer Care Helpline, your local authority civic amenity site or the retailer selling the product or a replacement product.

CONFORMITY INFORMATION

A sample of this product has been tested and found to be in conformity with the following European Directive: 2006/95/EC Low voltage Directive, 93/68/EEC CE Marking Directive, 2004/108/EC EMC Directive.

DYSON CUSTOMER CARE

THANK YOU FOR CHOOSING TO BUY A DYSON VACUUM CLEANER

If you have a question about your Dyson vacuum cleaner, call the Dyson Customer Care Helpline with your serial number and details of where and when you bought the vacuum cleaner, or contact us via the website. The serial number can be found on the main body of the vacuum cleaner behind the clear bin™. Most questions can be solved over the phone by one of our Dyson Customer Care Helpline staff.

If your vacuum cleaner needs service, call the Dyson Customer Care Helpline so we can discuss the available options. If your vacuum cleaner is under guarantee, and the repair is covered, it will be repaired at no cost.

PLEASE REGISTER AS A DYSON OWNER

To help us ensure you receive prompt and efficient service, please register as a Dyson owner. There are three ways to do this:

- Online at www.dyson.com
- By calling the Dyson Customer Care Helpline on UK 0800 298 0298 or IRL 01 475 7109.
- By completing and returning the enclosed form to us by mail. This will confirm ownership of your Dyson vacuum cleaner in the event of an insurance loss, and enable us to contact you if necessary.

LIMITED 5 YEAR GUARANTEE

TERMS AND CONDITIONS OF THE DYSON 5 YEAR LIMITED GUARANTEE.

WHAT IS COVERED

- The repair or replacement of your vacuum cleaner (at Dyson's discretion) if your vacuum cleaner is found to be defective due to faulty materials, workmanship or function within 5 years of purchase or delivery (if any part is no longer available or out of manufacture Dyson will replace it with a functional replacement part).
- Use of the vacuum cleaner in the UK and Republic of Ireland.

WHAT IS NOT COVERED

Dyson does not guarantee the repair or replacement of a product as a result of:

- Normal wear and tear (e.g. fuse, belt, brush bar, batteries etc).
- Accidental damage, faults caused by negligent use or care, misuse, neglect, careless operation or handling of the vacuum cleaner which is not in accordance with the Dyson Operating Manual.
- Blockages – please refer to the Dyson Operating Manual for details of how to unblock your vacuum cleaner.
- Use of the vacuum cleaner for anything other than normal domestic household purposes.
- Use of parts not assembled or installed in accordance with the instructions of Dyson.
- Use of parts and accessories which are not Dyson Genuine Components.
- Faulty installation (except where installed by Dyson).
- Repairs or alterations carried out by parties other than Dyson or its authorised agents.
- If you are in any doubt as to what is covered by your guarantee, please call the Dyson Customer Care Helpline on UK 0800 298 0298 or IRL 01 475 7109.

SUMMARY OF COVER

- The guarantee becomes effective at the date of purchase (or the date of delivery if this is later).
- You must provide proof of delivery/purchase before any work can be carried out on your vacuum cleaner. Without this proof, any work carried out will be chargeable. Please keep your receipt or delivery note.
- All work will be carried out by Dyson or its authorised agents.
- Any parts which are replaced will become the property of Dyson.
- The repair or replacement of your vacuum cleaner under guarantee will not extend the period of guarantee.
- The guarantee provides benefits which are additional to and do not affect your statutory rights as a consumer.

ABOUT YOUR PRIVACY

If your personal details change, if you change your mind about any of your marketing preferences or if you have any queries about how we use your information, please let us know by contacting Dyson Limited, Tetbury Hill, Malmesbury, Wiltshire, SN16 0RP England, or by calling the Dyson Customer Care Helpline on UK 0800 298 0298 or IRL 01 475 7109. Or you can email us at askdyson@dyson.co.uk

For more information on how we protect your privacy, please see our privacy policy on www.dyson.co.uk

PRODUCT INFORMATION

Net weight: 8.32kg, Voltage: 230-240V 50Hz, Rated power: 1400W.

Please note: Small details may vary from those shown.

This product is protected by the following intellectual rights:

PATENT/PATENT APPLICATION NUMBERS

EP 1119282, US 6,519,807, EP 1268076, US 6835222, EP 1361813,
US 7290309, EP 1370172, US 6991666, EP 1361812, US 7278181, EP 1361814,
US 7018439, EP 1361815, US 6974488, EP 04768834.6,
US 2007-0079579, US 2008-0105510, WO 2005/107553, EP 05757418.8,
US 11/631,109, GB 241296, EP 05757445.1, US 11/632,851, GB 2422093,
EP 06700228.7, US 2008-000004, GB 2440718, WO 2008/017803,
GB 2440716, WO 2008/017806, GB 2440515, WO 2008/015377,
GB 2440717, WO 2008/017804, WO 2008/017801, GB 2440514,
WO 2008/015378, GB 2440715, WO 2008/017802.

Equivalent patents, registered designs and applications exist in other countries.

IMPORTANT!

WASH FILTER



Wash filter with cold water at least every 3 months.



Dyson Customer Care

If you have a question about your Dyson vacuum cleaner, call the Dyson Customer Care Helpline with your serial number and details of where and when you bought the cleaner, or contact us via the Dyson website. The serial number can be found on the main body of the machine behind the clear bin™.

GB Dyson Customer Care

service@dyson.co.uk
0800 298 0298

Dyson Ltd, Tetbury Hill, Malmesbury, Wiltshire SN16 0RP.

IRL Dyson Customer Care

irelandservice@dyson.com
01 475 7109

The Connect Agency Ltd, Unit 2, Baldonnell Business Park,
Naas Road, Co. Dublin.

www.dyson.com





GUARANTEE FORM

Date of purchase / /

Country of purchase UK Ireland

Serial number

Title Surname

First name

Address

Postcode

e-mail

Telephone

From time to time, we'd like to tell you about new Dyson technology and services. If you'd prefer us **NOT** to keep in touch, please tick this box.

3 EASY WAYS TO REGISTER FOR YOUR FREE 5 YEAR GUARANTEE

REGISTER ONLINE



Visit our website to register your full parts and labour guarantee online.

www.dyson.com/register

REGISTER BY PHONE



Call our dedicated Helpline Open 7am–10pm. 7 days a week.

UK 0800 298 0298
IRL 01 475 7109

REGISTER BY MAIL



Complete and return the form to Dyson in the envelope supplied.

