

# DC31 MOTORHEAD

## ASSEMBLY

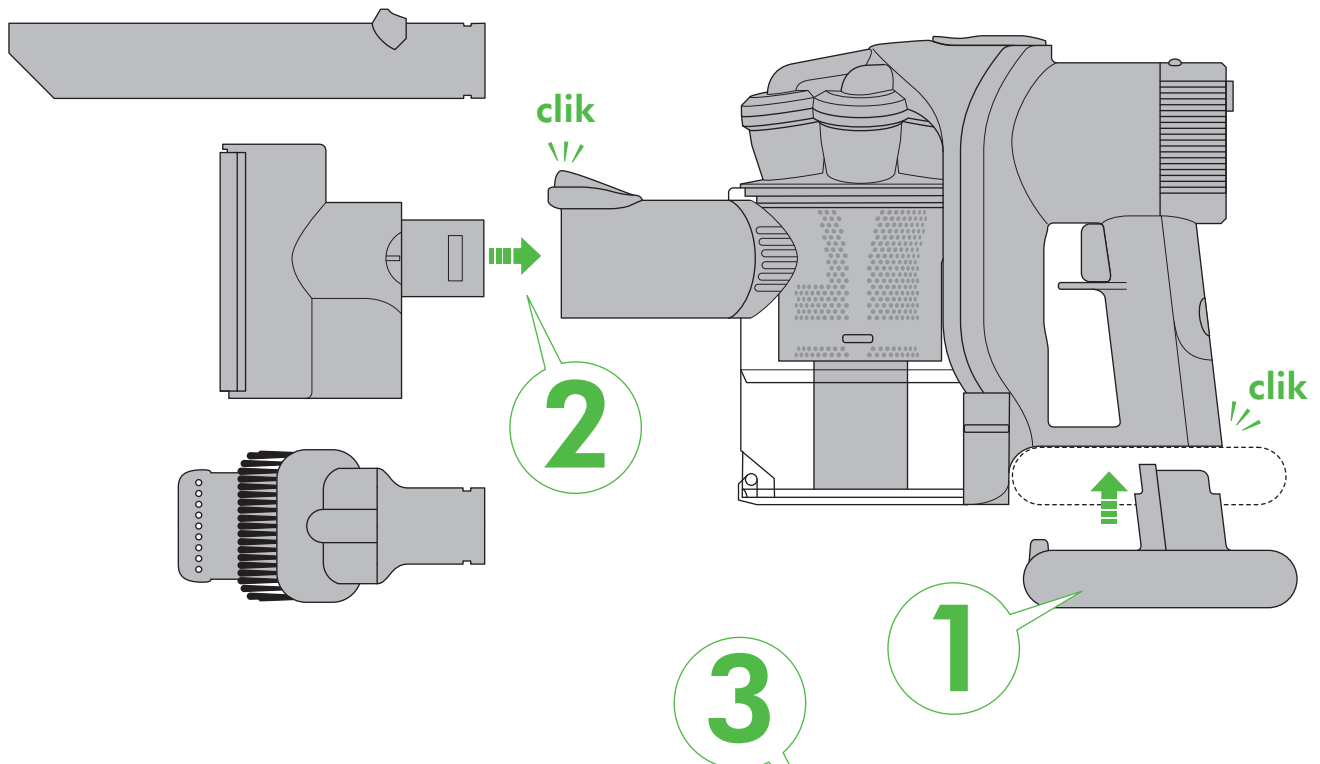

**WASH FILTER**  
Wash your filter with cold water regularly or as required.

**3.5 hrs**  
FULLY CHARGED

**REGISTER YOUR 2 YEAR GUARANTEE TODAY**

**BOOST**  
HIGH POWER = 05:00 mins  
**BOOST**  
LOW POWER = 07:00 mins

Your Dyson handheld vacuum will be covered for parts and labour for 2 years from the date of purchase, subject to the terms of the guarantee.

If you have a query about your Dyson handheld vacuum, call the Dyson Customer Care Helpline quoting the serial number and details of where/when you bought the Dyson handheld vacuum. The serial number can be found on the main body of the handheld vacuum, behind the filter.

Most queries can be solved over the phone by one of our Dyson Customer Care Helpline staff.

Visit our website to register your full parts and labour guarantee online (Australia only).  
[www.dyson.com.au/register](http://www.dyson.com.au/register)

Note your serial number for future reference

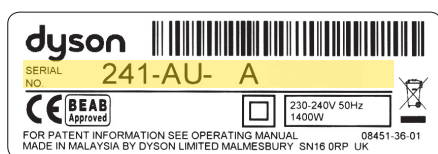

This illustration is for example purposes only.

### 3 EASY WAYS TO REGISTER YOUR 2 YEAR GUARANTEE



**REGISTER ONLINE**

Visit our website to register your full parts and labour guarantee online (Australia only).

[www.dyson.com.au/register](http://www.dyson.com.au/register)



**REGISTER BY PHONE**

Call our dedicated Helpline.

**AU 1800 239 766**  
**NZ 0800 397 667**  
**SG 7000 435 7546**  
**ID 021 707 39766**



**REGISTER BY MAIL**

Complete and return the form to Dyson in the envelope supplied.

# IMPORTANT SAFETY PRECAUTIONS

## READ ALL INSTRUCTIONS BEFORE USING THIS APPLIANCE

When using an electrical appliance, basic precautions should always be followed, including the following:



## WARNING

### TO REDUCE THE RISK OF FIRE, ELECTRIC SHOCK OR INJURY:

1. Do not charge the Dyson handheld vacuum outdoors, in a bathroom or within 10 feet of a pool.
2. Do not use outdoors or on wet surfaces.
3. Do not allow to be used as a toy. Close attention is necessary when used by or near children.
4. Use only as described in this manual. Use only Dyson recommended accessories and replacement parts.
5. Do not use with damaged cable or charger. If the Dyson handheld vacuum is not working as it should, has been dropped, damaged, left outdoors, or dropped into water, contact the Dyson helpline.
6. Do not unplug by pulling on cable. To unplug, grasp the charger, not the cable.
7. Do not handle the charger, including the charger terminals or Dyson handheld vacuum with wet hands.
8. Do not put any object into openings. Do not use with any opening blocked; keep free of dust, lint, hair, and anything that may reduce air flow.
9. Keep hair, loose clothing, fingers, and all parts of body away from openings and moving parts.
10. Use extra care when cleaning on stairs.
11. Do not use to pick up flammable or combustible liquids, such as petrol, or use in areas where they may be present.
12. Do not pick up anything that is burning or smoking, such as cigarettes, matches, or hot ashes.
13. Do not use without clear bin and filters in place.
14. Use only the charger supplied by the manufacturer to recharge.
15. Unplug the charger from socket before maintenance.
16. Do not use with an extension cable.
17. This Dyson handheld vacuum is not intended for use by persons (including children) with reduced physical, sensory or mental capabilities, or lack of experience and knowledge, unless they have been given supervision or instruction concerning use of the Dyson handheld vacuum by a person responsible for their safety.
18. Do not incinerate this Dyson handheld vacuum even if it is severely damaged. The batteries may explode in a fire.
19. Always turn off the Dyson handheld vacuum before connecting or disconnecting the motorized brush bar.

## SAVE THESE INSTRUCTIONS

THIS HANDHELD VACUUM IS INTENDED FOR DOMESTIC HOUSEHOLD AND CAR USE ONLY.



Do not use near naked flame.



Do not store near heat source.



Do not pick up water or liquids.



Do not pick up burning objects.



Do not pull on the cable.

### Looking for blockages

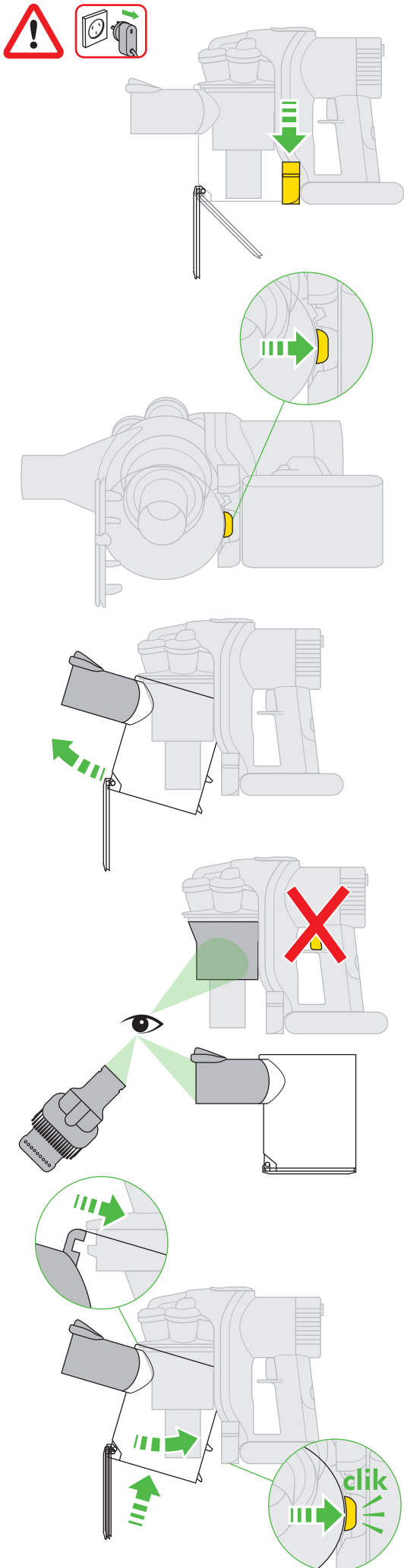

### Power

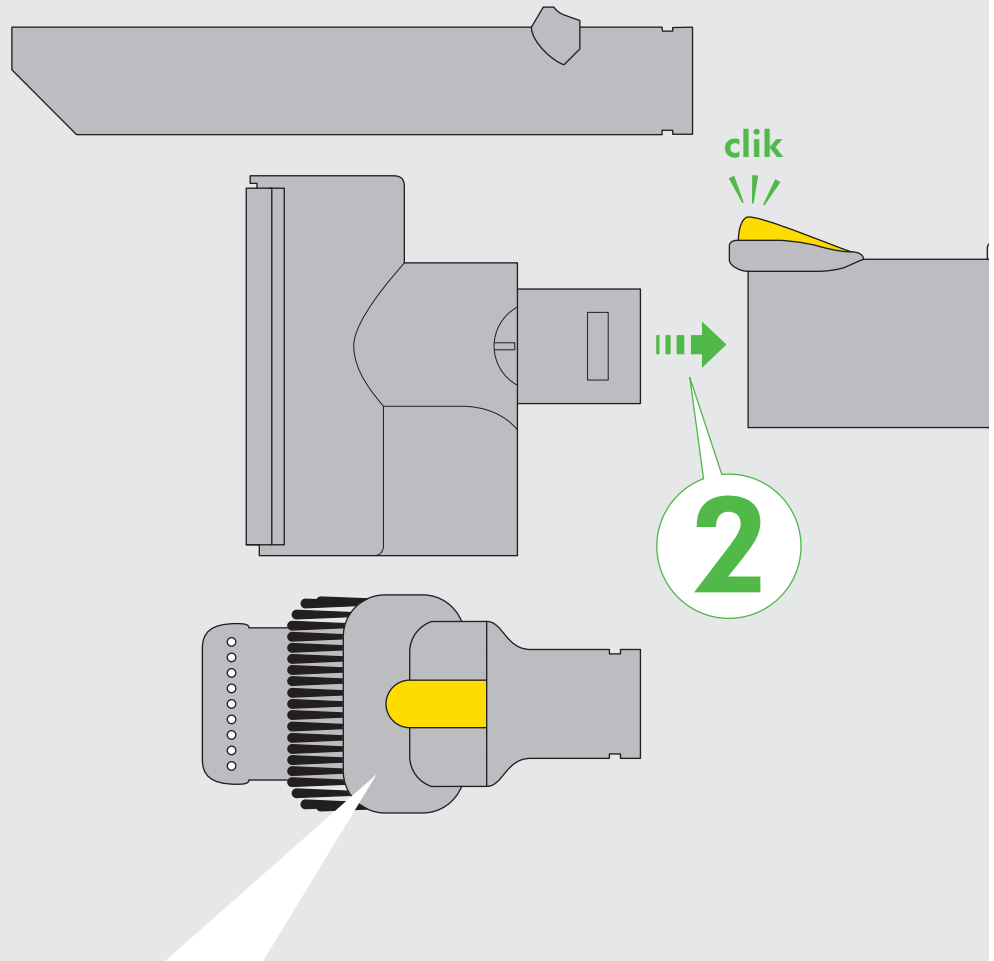
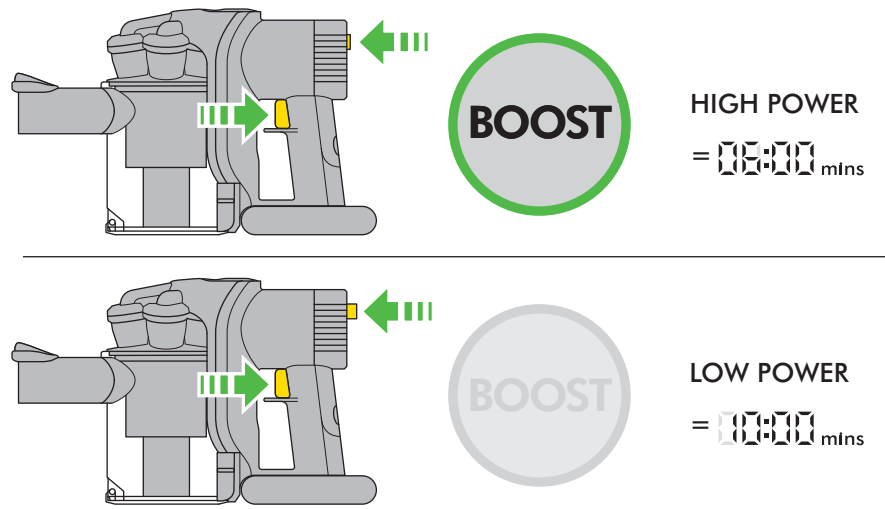

### Combination accessory tool

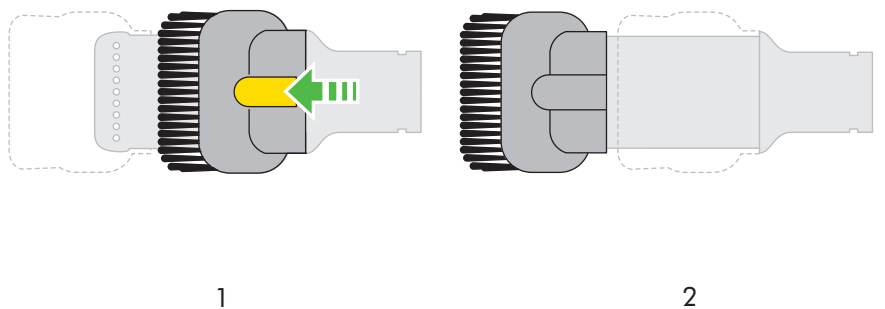

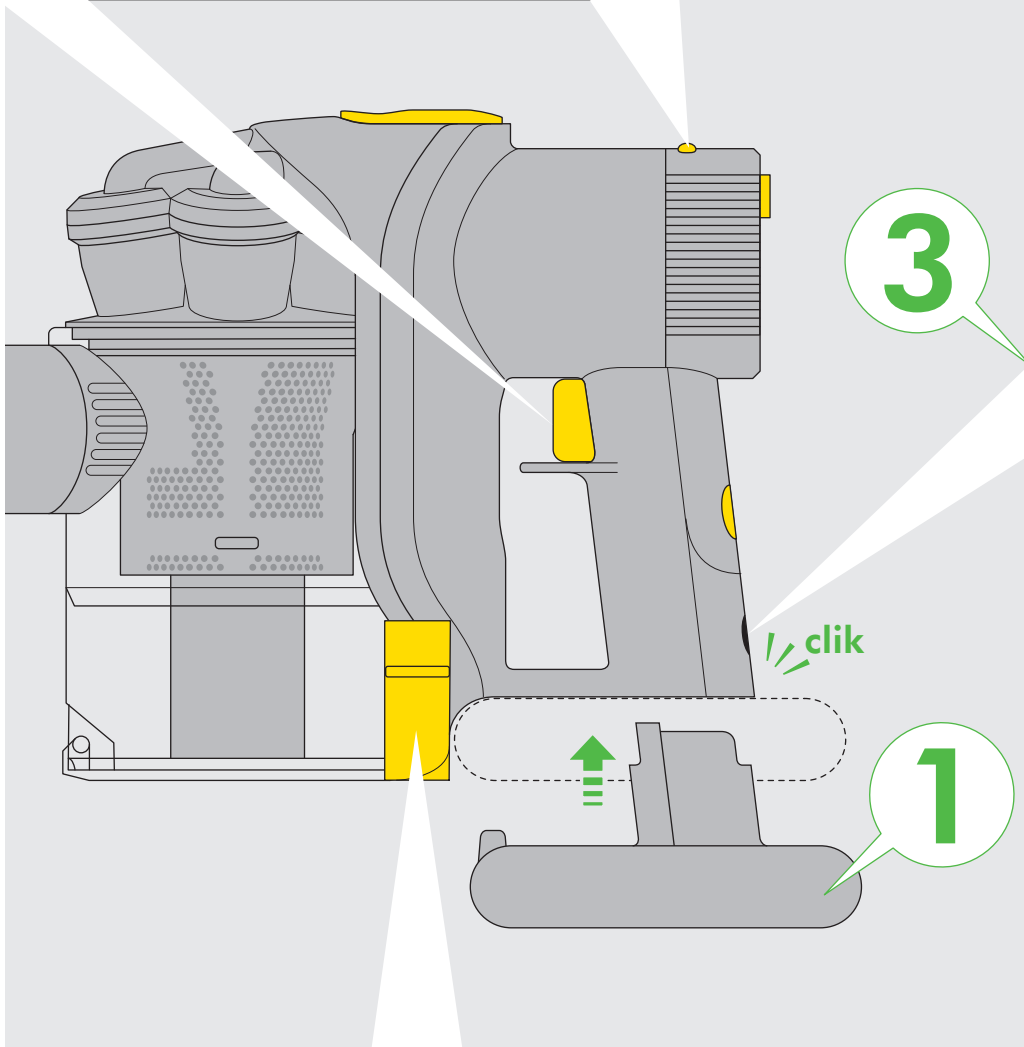
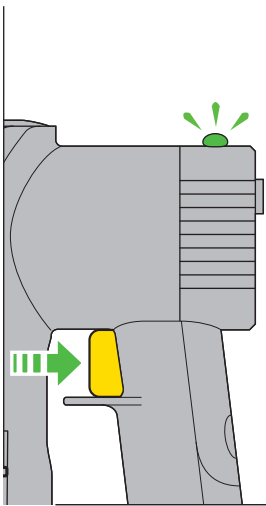
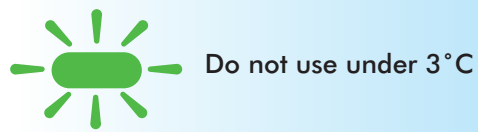
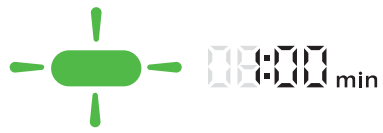

Charging

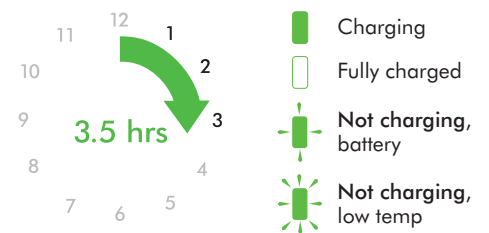
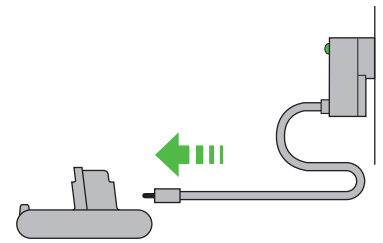
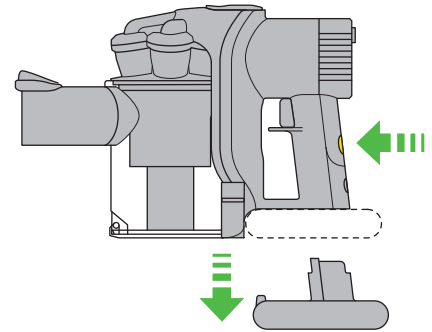
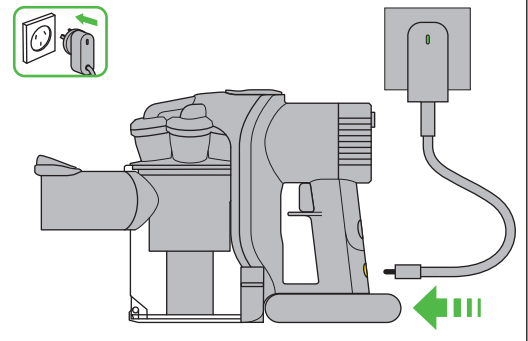

Emptying the clear bin

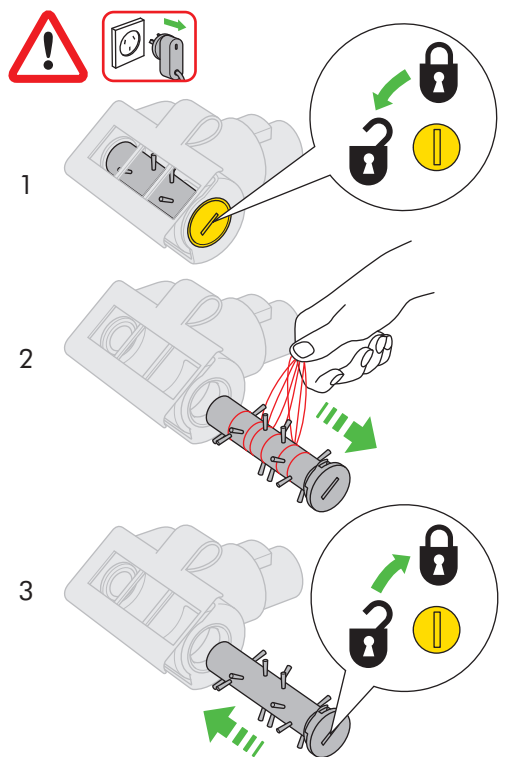
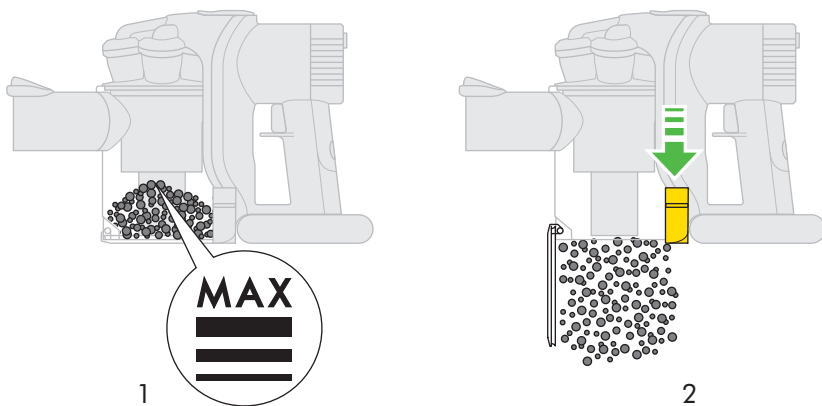

# IMPORTANT!

## WASH FILTER

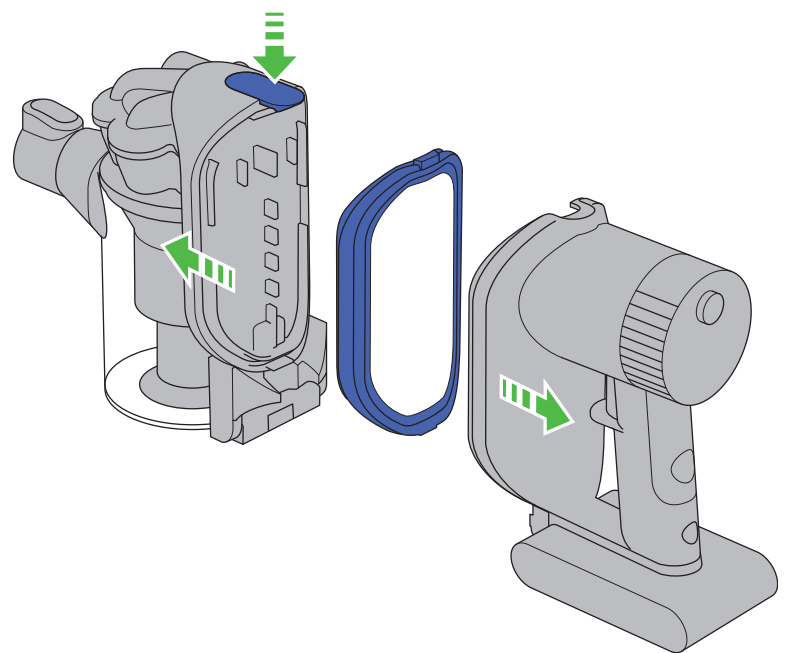
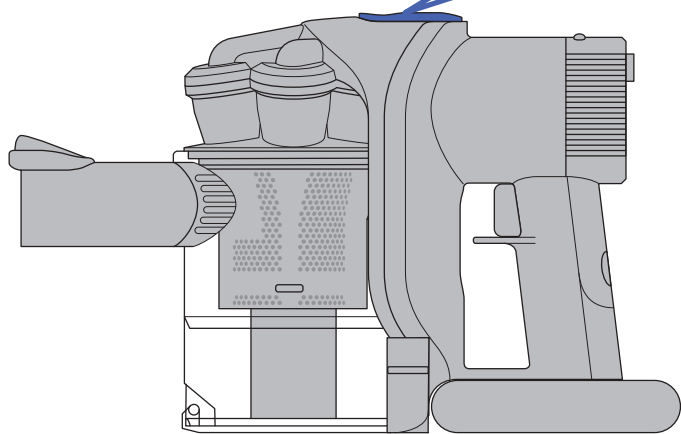
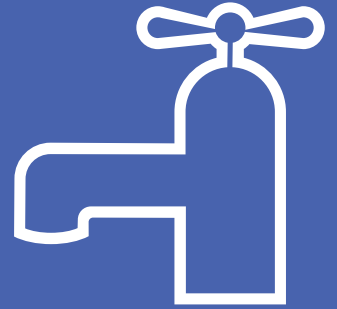

Wash your filter with cold water regularly or as required.

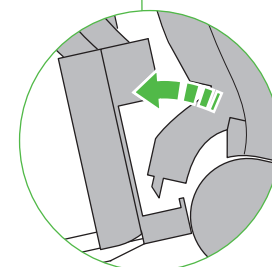
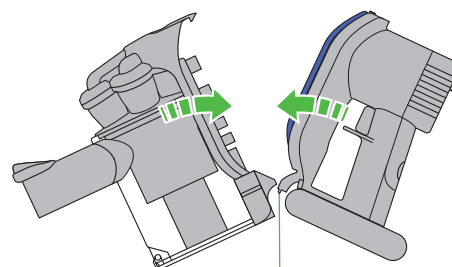
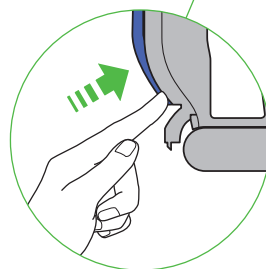
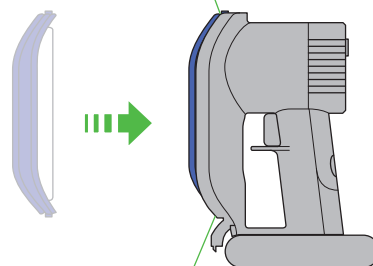
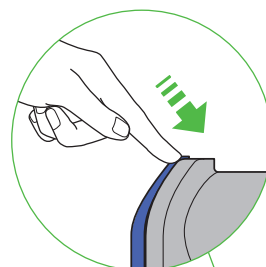
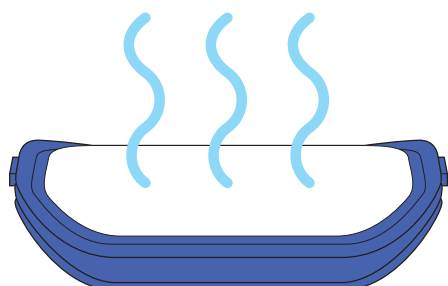
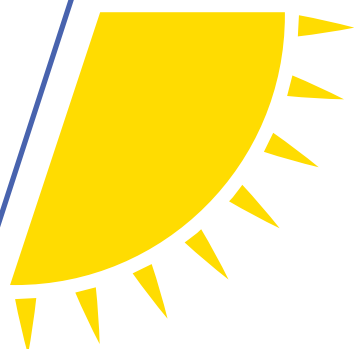
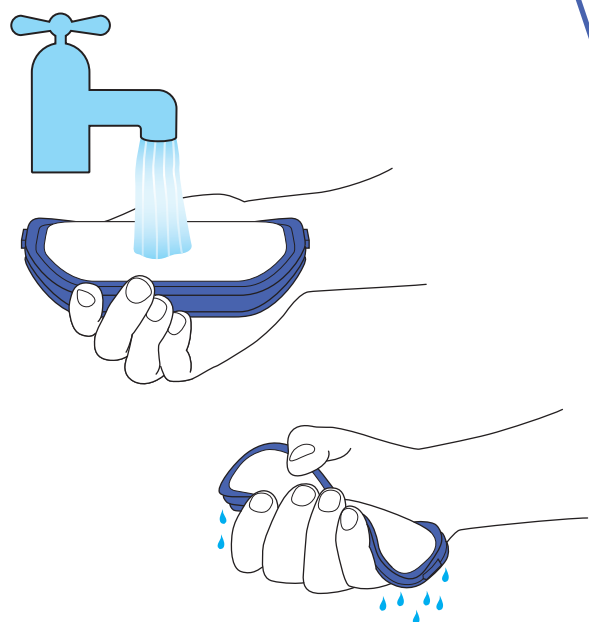

## USING THE DYSON HANDHELD VACUUM

### CAUTION:

- Take caution not to engage battery release button during normal operation.
- Dirt and debris may be released from the Dyson handheld vacuum if it is turned upside down. Ensure the Dyson handheld vacuum remains upright in use and storage.
- Do not operate the Dyson handheld vacuum while checking for blockages.

### PLEASE NOTE:

- Do not carry out any maintenance or repair work other than that shown in this Dyson Operating Manual or advised by the Dyson Customer Care Helpline.
- This Dyson handheld vacuum is designed for domestic indoor and car use only. Do not use it while the car is in motion or while driving.
- Do not press down on the nozzle with excessive force when using the Dyson handheld vacuum as this may cause damage.
- If the motor overheats, the Dyson handheld vacuum will cut out automatically. Leave it to cool for at least an hour and check for blockages before restarting.
- Fine dirt such as flour or plaster dust should only be vacuumed in very small amounts.
- Consult your flooring manufacturer's recommended instructions before vacuuming and caring for your flooring, rugs and carpet.
- The brush bar on the handheld can damage certain carpet types and floors. Some carpets will fuzz if a rotating brush bar is used when vacuuming. If this happens, we recommend vacuuming without the Motorhead and consulting with your flooring manufacturer.

## TROUBLESHOOTING – DYSON HANDHELD VACUUM

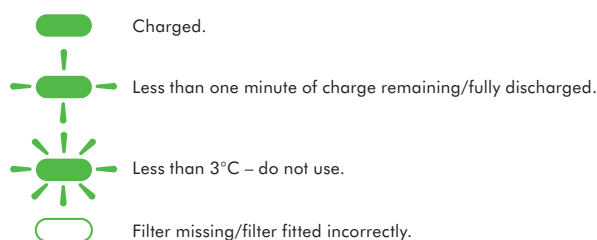

## EMPTYING THE CLEAR BIN

### CAUTION:

- Switch off the Dyson handheld vacuum and disconnect from charger before emptying the clear bin.
- Empty as soon as the dirt reaches the level of the MAX mark – do not overfill.
- To release the dirt, push the button at the side of the clear bin as shown.

### PLEASE NOTE:

- Do not use the Dyson handheld vacuum without the clear bin in place.

## CLEANING THE CLEAR BIN

### CAUTION:

- Ensure the clear bin is completely dry before replacing.

### PLEASE NOTE:

- To remove the clear bin, push the release button on the underside of the Dyson handheld vacuum as shown.
- Use only cold water to clean the clear bin. Do not use detergents, polishes or air fresheners.
- Do not put the clear bin in a dishwasher.

## WASHING THE FILTER

### CAUTION:

- Switch 'OFF' and disconnect from charger before removing the filter.
- Ensure filter is completely dry before refitting to the Dyson handheld vacuum.

### PLEASE NOTE:

- This Dyson handheld vacuum has one filter, located as shown. It is important to check your filter and wash with cold water regularly or as required, to maintain performance. Please leave to dry completely for 12 hours.
- The filter may require more frequent washing if vacuuming fine dust.
- Do not use detergents to clean the filter.
- Do not put the filter in the dishwasher, washing machine, tumble dryer, oven, microwave or near an open flame.

## LOOKING FOR BLOCKAGES

### CAUTION:

- Switch off the Dyson handheld vacuum and disconnect from charger before looking for blockages.
- Beware of sharp objects when clearing blockages.
- Refit all parts of the Dyson handheld vacuum securely before using.

### PLEASE NOTE:

- Clearing blockages is not covered by the Dyson handheld vacuum's guarantee. If any part of the Dyson handheld vacuum becomes blocked, it may overheat and then automatically shut off.
- Unplug the Dyson handheld vacuum and leave to cool down. Clear blockage before restarting.

## CLEARING BRUSH BAR OBSTRUCTIONS

### CAUTION:

Switch off the Dyson handheld vacuum and disconnect from charger before clearing brush bar obstructions. If your brush bar is obstructed, it may stop spinning. If this happens you will need to remove the brush bar as shown and clear any obstructing debris.

## CHARGING AND STORING THE DYSON HANDHELD VACUUM

The Dyson handheld vacuum will turn off if the battery temperature is below 3°C. This is designed to protect the motor and battery of the product. Do not charge the Dyson handheld vacuum and then move it to an area with a temperature below 3°C for storage purposes.

## TROUBLESHOOTING – CHARGER

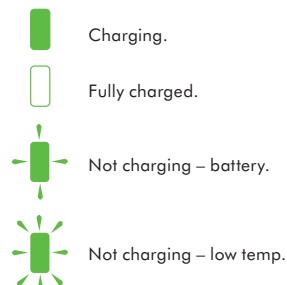

## BATTERY SAFETY INSTRUCTIONS

Use only Dyson batteries and charging unit for the Dyson handheld vacuum. The battery is a sealed unit and under normal circumstances poses no safety concerns. In the unlikely event that liquid leaks from the battery, do not touch the liquid and observe the following precautions:

- Skin contact – can cause irritation. Wash with soap and water.
- Inhalation – can cause respiratory irritation. Expose to fresh air and seek medical advice.
- Eye contact – can cause irritation. Immediately flush eyes thoroughly with water for at least 15 minutes. Seek medical attention.
- Disposal – wear gloves to handle the battery and dispose of immediately following local ordinances or regulations.

### CAUTION:

- The battery used in this device may present a risk of fire or chemical burn if mistreated. Do not disassemble, short contacts, heat above 140° F (60° C), or incinerate. Replace battery with a Dyson battery only, use of any other battery may present a risk of fire or explosion. Dispose of used battery promptly. Keep away from children. Do not disassemble and do not dispose of in fire.
- The battery must be removed from the Dyson handheld vacuum before it is scrapped.
- The battery is to be disposed of safely.
- The Dyson handheld vacuum must be disconnected from the supply mains when removing the battery.
- Battery can be charged on or off the handheld vacuum. Take caution when removing the battery.

The symbol  on the product or on its packaging indicates that this product should not be treated as household waste. Instead it should be handed over to the applicable collection point for the recycling of electrical and electronic equipment – this may be your local civic amenity site. By ensuring this product is disposed of correctly, you will help prevent potential negative consequences for the environment and for human health, which could otherwise be caused by inappropriate waste handling of this product. For more detailed information about recycling of this product, please contact the Dyson Customer Care Helpline or your local authority civic amenity site.



## 2 YEAR GUARANTEE - TERMS AND CONDITIONS

To help us ensure you receive prompt and efficient service, please register as a Dyson owner. There are three ways to do this:

- Online (Australia only) at [customercare@dyson.com.au](mailto:customercare@dyson.com.au)
- By calling the Dyson Customer Care Helpline.
- By completing and returning the enclosed form to us by mail. This will confirm ownership of your Dyson handheld vacuum in the event of an insurance loss and enable us to contact you if necessary.

## DYSON CUSTOMER CARE

If you have a query about your Dyson handheld vacuum call the Dyson Customer Care Helpline and quote your serial number or contact us via the Dyson website. The serial number can be found on the main body of the handheld vacuum, behind the filter.

Most queries can be solved over the phone by one of our Dyson Customer Care Helpline staff.

If your Dyson handheld vacuum needs a service, call the Dyson Customer Care Helpline so we can discuss the available options.

## DYSON CUSTOMER CARE DETAILS

Any queries – just call the Dyson Customer Care Helpline

AU: 1800 239 766 (Mon-Fri 8:00am to 6:00pm EST,

Sat-Sun 8:30am to 4:00pm EST) [www.dyson.com.au](http://www.dyson.com.au)

NZ: 0800 397 667 (Mon-Fri 8:30am to 5:00pm) [www.dyson.co.nz](http://www.dyson.co.nz)

SG: 7000 435 7546 (Mon-Fri 9:00am to 6:00pm) [www.dyson.com.sg](http://www.dyson.com.sg)

ID: 021 707 39766 (Mon-Fri 9:00am to 5:00pm) [www.dyson.co.id](http://www.dyson.co.id)

## SUMMARY OF COVER

Terms and conditions of the Dyson 2 year guarantee.

- The guarantee becomes effective from the date of purchase.
- All work will be carried out by Dyson Appliances (Aust) Pty Ltd, Avery Robinson Ltd (NZ), Singapore's authorised agent – Service @Home Pte Ltd, Indonesia's authorised agent – PT Higienis Indonesia or their authorised agents.
- Any parts replaced will become the property of Dyson Appliances (Aust) Pty Ltd.
- The repair or replacement of your Dyson handheld vacuum under guarantee will not extend the period of guarantee.
- The guarantee provides benefits which are additional to and do not affect your statutory rights as a consumer.
- You must provide proof of purchase before any work can be carried out on your Dyson handheld vacuum. Without this proof, any work carried out will be chargeable. Please keep your receipt.

## WHAT IS COVERED

- The repair or replacement of your Dyson handheld vacuum if it is found to be defective due to faulty materials, workmanship or function within 2 years of purchase (if any part is no longer available or out of manufacture, Dyson will replace it with a functional replacement part).

## WHAT IS NOT COVERED

Dyson shall not be liable for costs of repair or replacement of a product incurred as a result of:

- Normal wear and tear.
- Reduction in battery discharge time due to battery age or use.
- Industrial use of the Dyson handheld vacuum such as vacuuming gyprock dust or builders dust may void your guarantee.
- Accidental damage, faults caused by negligent use or care, neglect, careless operation or handling of the Dyson handheld vacuum which is not in accordance with this Dyson Operating Manual.
- Blockages – please refer to this Dyson Operating Manual for details on how to unblock your Dyson handheld vacuum.
- Use of the Dyson handheld vacuum for anything other than normal domestic purposes.
- Use of parts not assembled or installed in accordance with the instructions of Dyson.
- Use of parts and accessories other than those produced or recommended by Dyson.
- External sources such as transit damage or weather.
- Repairs or alterations carried out by parties other than Dyson or its authorised agents.
- If you are in any doubt as to what is covered by your guarantee, please call the Dyson Customer Care Helpline on:  
Australia 1800 239 766  
New Zealand 0800 397 667  
Singapore 7000 435 7546  
Indonesia 021 707 39766

## ABOUT YOUR PRIVACY

Dyson may use this information for future marketing and research purposes (including sending commercial electronic messages) and may disclose it to third parties for the purposes of providing the services you have requested or to our business partners or professional advisers. If you wish to access your personal information or see our full privacy policy, please contact us at: [customercare@dyson.com.au](mailto:customercare@dyson.com.au)

## PRODUCT INFORMATION

Net weight: 1.52kg

Please note: Small details may vary.

This product is protected by the following intellectual property rights:

## PATENTS/APPLICATIONS

CA 2544609; JP 2007-508934; US 2007-0079579; AU 2004294771; AU 2002226556; CA 2,439,250; EP 1370172; JP 4002185; US 6991666; AU 2002225207; EP 1361814; JP 3860541; US 7018439; AU 2001240894; EP 1268076; JP 2003-528704; US 6,835,222; AU 2002-225232; EP 1361815; JP 3940082; US 6,974,488; EP 1748848; JP 2007-534377; US 2007-0175189; WO 2005/110608; WO 2008/009884; WO 2008/009891; WO 2008/015377; WO 2008/015378; WO 2008/009886; WO 2008/009888; WO 2008/009883; WO 2008/035034; GB 2440515; GB 2440514; GB 2440126; GB 2440109; GB 2440107; GB 2442033.

## DESIGNS/DESIGN APPLICATIONS

GB 3025398; GB 3025399; GB 3025400; GB 3025401; GB 3025402; GB 3025403; GB 3025404; EU 651849; GB 4004309.

Equivalent patents, registered designs and applications exist in other countries.

# IMPORTANT!

## WASH FILTER



Wash your filter with cold water regularly or as required.

Register for a filter wash reminder by email (Australia only):  
[customercare@dyson.com.au](mailto:customercare@dyson.com.au)



### Dyson Customer Care

If you have a question about your Dyson handheld vacuum, call the Dyson Customer Care Helpline with your serial number and details of where and when you bought the Dyson handheld vacuum, or contact us via the Dyson website. The serial number can be found on the main body of the Dyson handheld vacuum, behind the filter.

**AU Dyson Customer Care**  
[customercare@dyson.com.au](mailto:customercare@dyson.com.au)  
**1800 239 766**  
Dyson Appliances (Aust) Pty Ltd.,  
PO Box 2835,  
Taren Point, NSW 2229,  
Australia  
[www.dyson.com.au](http://www.dyson.com.au)

**NZ Dyson Customer Care**  
[dyson@averyrobinson.co.nz](mailto:dyson@averyrobinson.co.nz)  
**0800 397 667**  
Avery Robinson Ltd.,  
Unit F, 151D Marua Road,  
Ellerslie, Auckland 1051,  
New Zealand  
[www.dyson.co.nz](http://www.dyson.co.nz)

**SG Dyson Customer Care**  
[Singapore@dyson.com](mailto:Singapore@dyson.com)  
**7000 435 7546**  
Service @ Home Pte Limited,  
2 Leng Kee Road, #04-09A Thye Hong Centre,  
Singapore 159086  
[www.dyson.com.sg](http://www.dyson.com.sg)

**ID Dyson Customer Care**  
[service@higienis.com](mailto:service@higienis.com)  
**021 707 39766**  
PT. Higienis Indonesia  
Permata Plaza Top Floor TF-04,  
Jl. M. H. Thamrin Kav. 57,  
Jakarta 10350  
Indonesia  
[www.dyson.co.id](http://www.dyson.co.id)

Please take a few moments to answer our questions.  
They will help us develop new products for the future.

1 This handheld is...

- My first handheld
- A replacement handheld
- An additional handheld

2 Which brand of handheld are you replacing or adding to?

- Dyson
- Piranha
- Electrolux
- Breville
- Black and Decker
- Other, please specify

3 Why did you choose to buy a Dyson handheld?

(Please rank in order, 1-5, 1 being the most important).

- Dyson reputation
- Good for pet hair pick-up
- No loss of suction
- Features
- Price/special offer
- Store staff recommendation
- Picks up more dust than others
- Friend/family recommendation
- Other

4 Where did you first hear about Dyson?

- From friends and family
- Saw it on the internet
- From a TV/magazine advert
- Saw it in a store catalogue
- Saw it in a store
- Recommended by salesperson

5 Where did you look for additional information?

- Brand website
- Online reviews and forums
- Retail staff opinion
- Retail catalogue
- Didn't do any additional research

6 Do you own a Dyson vacuum cleaner?

- Yes
- No

7 What is your average household income?

- Less than \$45,000
- Between \$45,000-\$74,000
- Between \$75,000-\$100,000
- Over \$100,000

8 Do you have any household pets?

- Dog
- Cat
- No
- Other

9 Does anyone in your household suffer from any of the following?

- Asthma
- Allergies
- No

10 To which age group do you belong?

- 16-24
- 25-34
- 35-44
- 45-54
- 55-64
- 65+

11 Would you recommend a Dyson handheld to your family?

- Yes
- No

12 Do you have children?

- Pre-school
- Aged 5-17 years
- Aged +17 years
- Children no longer at home
- Pregnant
- No children

13 Which best describes your house?

(Tick one from each column).

- |   |  |
|---|--|
| <input type="checkbox"/> Own house              | <input type="checkbox"/> Share accommodation |
| <input type="checkbox"/> Rented house           | <input type="checkbox"/> Up to 2 beds        |
| <input type="checkbox"/> Own apartment/villa    | <input type="checkbox"/> 3-4 beds            |
| <input type="checkbox"/> Rented apartment/villa | <input type="checkbox"/> More than 4 beds    |
| <input type="checkbox"/> Live with parents      |  |

THANK YOU FOR YOUR TIME





# GUARANTEE FORM

Date of purchase  /  /

Country of purchase  Australia  New Zealand  
 Singapore  Indonesia

Serial number

Title  Surname

First name

Address

Postcode

e-mail

Telephone  Mobile

Store of purchase

Warranty  
Did you purchase an extended warranty?  Yes  No  
If yes, for what additional period?  1 year  2 years  3 years

As a Dyson owner, you can hear about Dyson inventions and ideas before anyone else. If you wish to be contacted, please let us know how we may do this.

By mail Yes  No  By e-mail Yes  No   
By phone Yes  No  By text message Yes  No

Privacy Act  
Dyson may use this information for future marketing and research purposes (including sending commercial electronic messages) and may disclose it to third parties for the purposes of providing the services you have requested or to our business partners or professional advisers. If you wish to access your personal information or see our full privacy policy, please contact us at [customer@dyson.com.au](mailto:customer@dyson.com.au)  
If you do not wish to receive marketing information by these methods from Dyson please tick this box.

## 3 EASY WAYS TO REGISTER YOUR 2 YEAR GUARANTEE



**REGISTER ONLINE**  
Visit our website to register your full parts and labour guarantee online (Australia only).  
[www.dyson.com.au/register](http://www.dyson.com.au/register)



**REGISTER BY PHONE**  
Call our dedicated Helpline.  
**AU 1800 239 766**  
**NZ 0800 397 667**  
**SG 7000 435 7546**  
**ID 021 707 39766**



**REGISTER BY MAIL**  
Complete and return the form to Dyson in the envelope supplied.

